

# Soil-geosynthetic interaction: Obtaining strength parameters for design

---

Professor Neil Dixon

Loughborough University, UK

# Contents

- Importance of interface shear behaviour
- Methods of measurement
- Factors influencing interface behaviour
- Which parameters should be used in design?
- Variability of measured behaviour
- Obtaining interface shear strength parameters for design
- What are the implications of variability on design?
- Summary and the future

# The presentation will not cover....

- Interaction between grids and soil
- Pull out testing
- Specific issues related to testing GCLs
- And lots of other things.....
- Experience of audience?

# Importance of interface shear behaviour

# Interface shear strength

- Why is knowledge of interface strength important?
  - Geosynthetics introduce a potential weak plane
  - Overall stability is controlled by shear strength developed between geosynthetic/geosynthetic and geosynthetic/soil
  - Integrity of the geosynthetic is controlled by shear strength either side

# Stability and integrity

- Stability

- Ultimate limit state
- Complete loss of stability
- “Large” scale movement

- Integrity

- Serviceability limit state
- Loss of function (e.g. overstressing, tearing, increased permeability etc.)
- “Small” scale movement

# Design issues: Stability, unconfined



# Interface shear strength

- For a soil:

- $\tau = c' + \sigma_n' \cdot \tan\phi'$

where  $c'$  and  $\phi'$  are the shear strength parameters, the cohesion intercept and the friction angle

- For a geosynthetic:

- $\tau = \alpha' + \sigma_n' \cdot \tan\delta'$

where  $\alpha'$  and  $\delta'$  are the interface shear strength parameters, the cohesion intercept and the friction angle



# Peak and residual shear strength

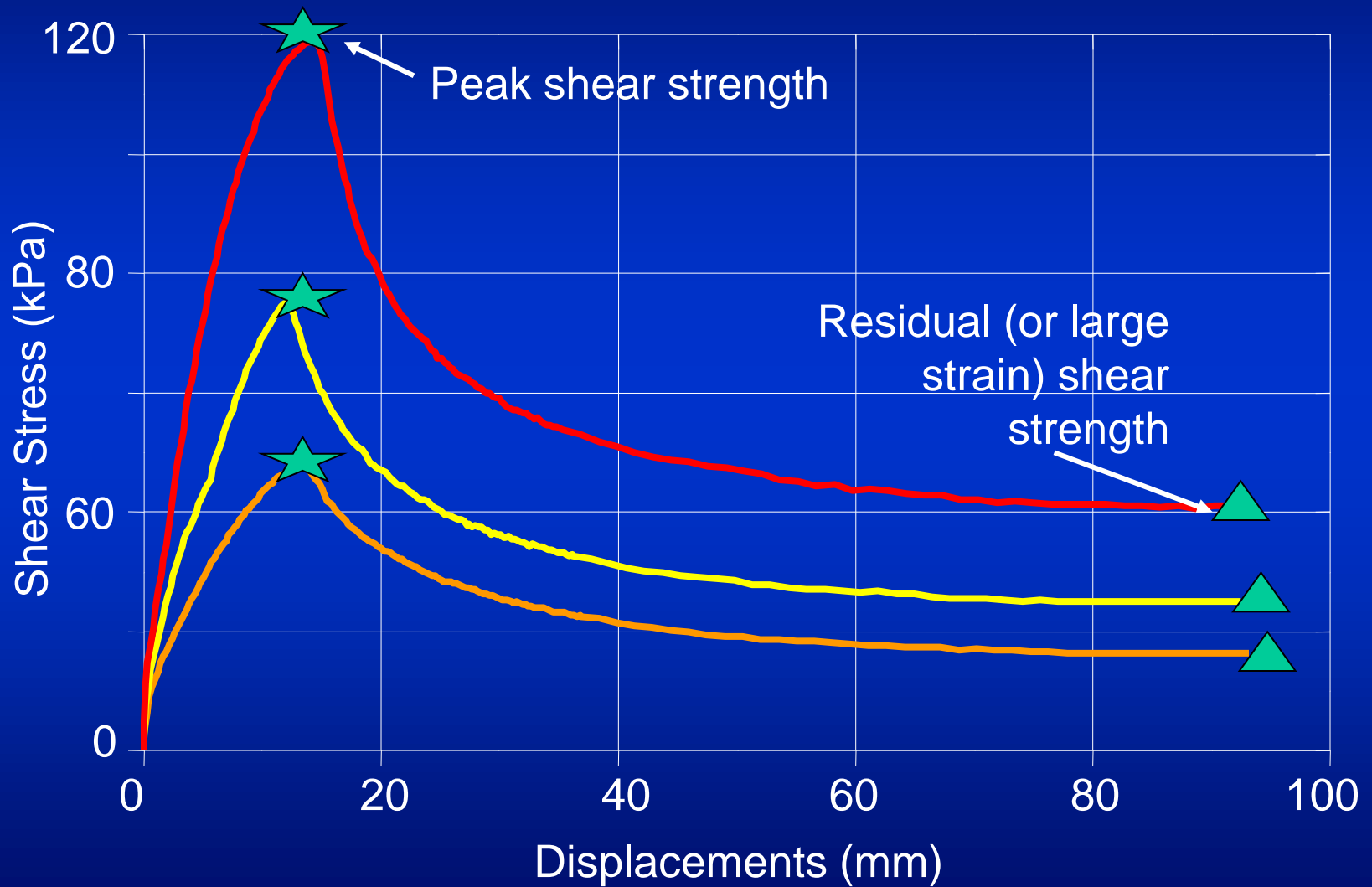

# Peak and residual shear strength

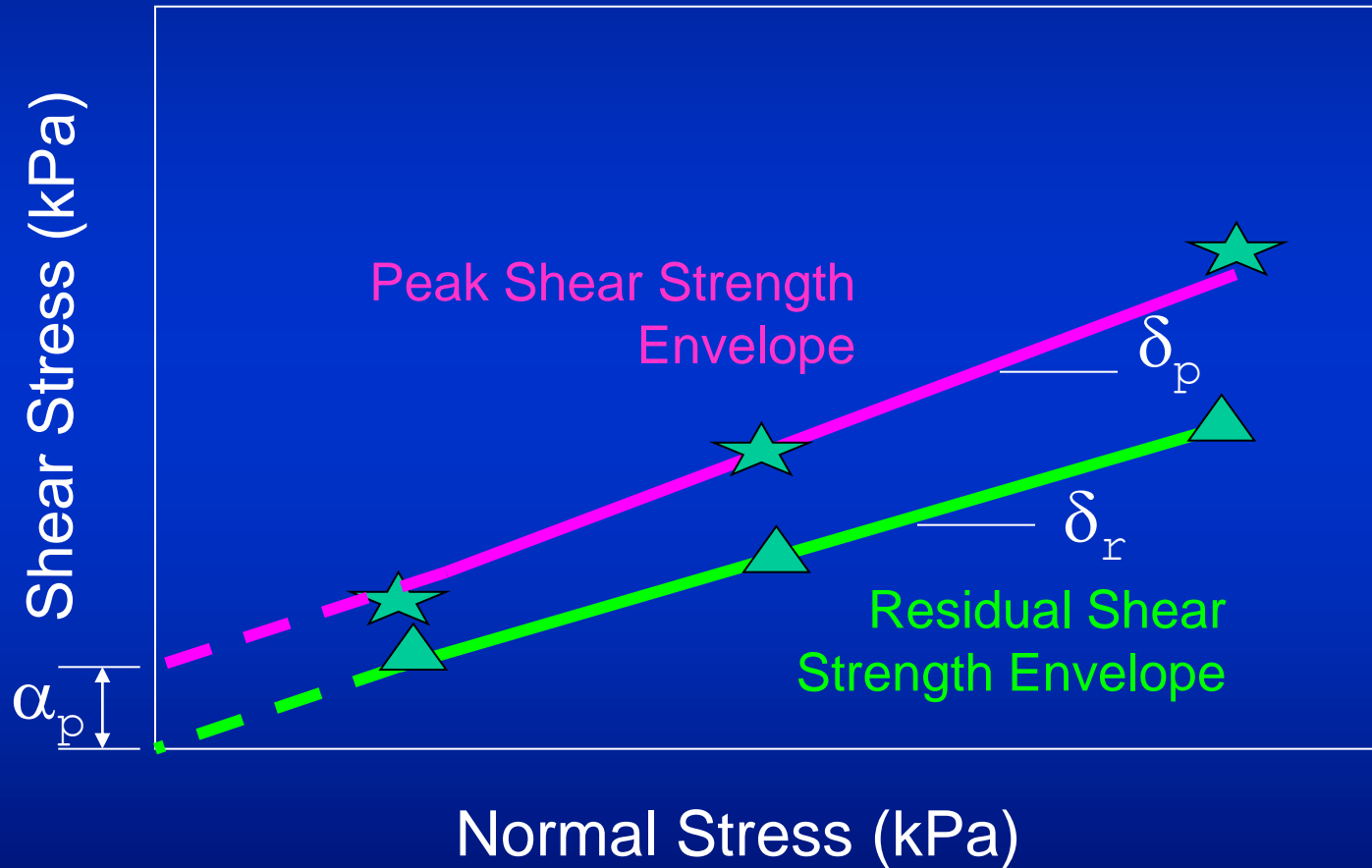

# Methods of measurement

# Factors influencing interface strength

- Material properties: Geosynthetic and soil
- Testing apparatus design and size
- Normal stress
- Shearing rate
- Geosynthetic attachment
- Moisture conditions
- Drainage conditions
- Temperature.....

# Common interface shear behaviour (after Marr 2001)

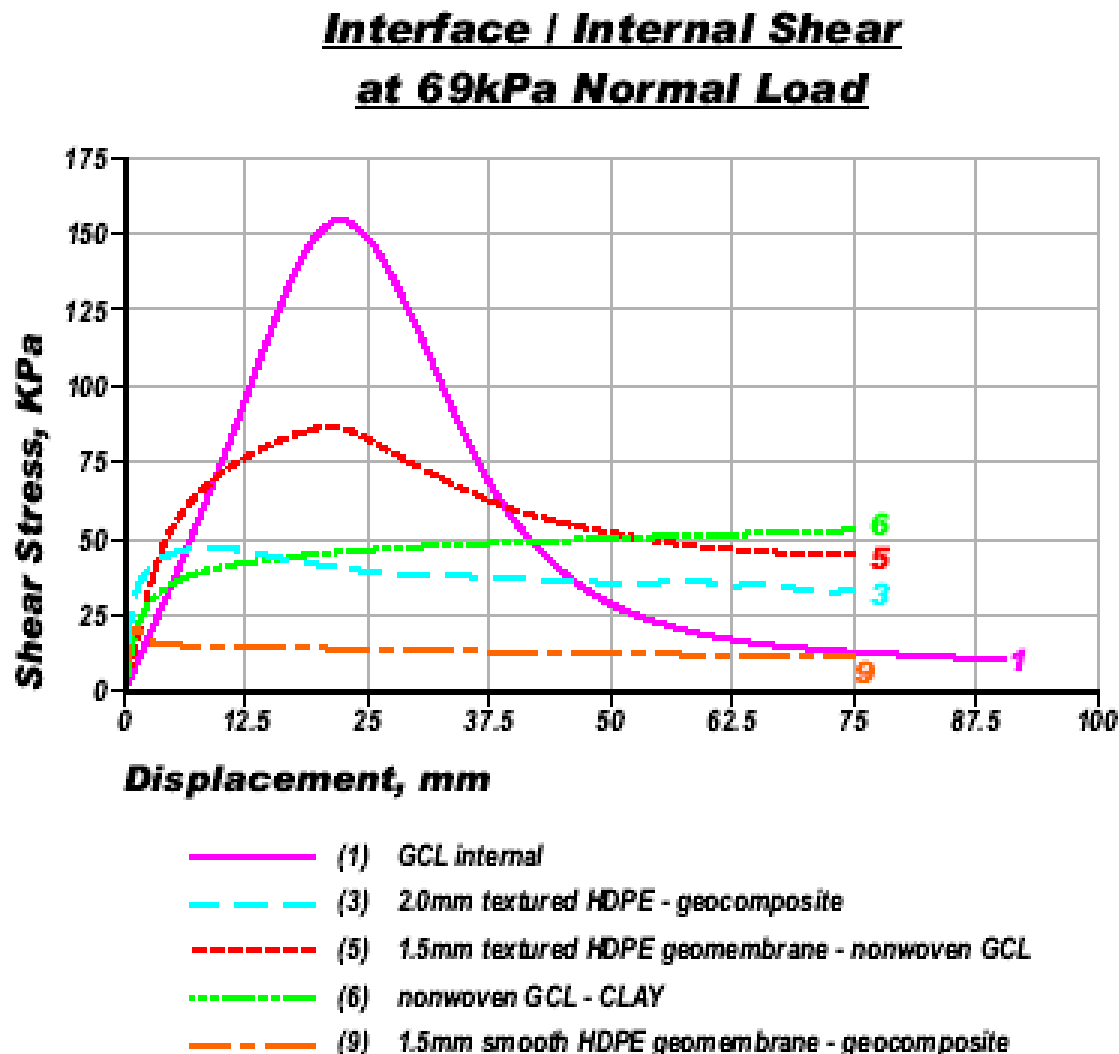

# Measurement: Direct shear

- Small boxes  $60 \times 60 \text{mm}^2$  and  $100 \times 100 \text{mm}^2$  (index testing and possibly acceptable for some interfaces)
- Large boxes  $300 \times 300 \text{mm}^2$  and  $300 \times 400 \text{mm}^2$  (performance testing, most commonly used)
- Full range of normal stresses (e.g.  $5 \text{kPa}$  to  $+400 \text{kPa}$ )
- Granular soils and large geosynthetic samples can be accommodated
- Easy to use but limited displacements
- Wide range of designs (influences measured behaviour)

# Direct shear apparatus (DSA)

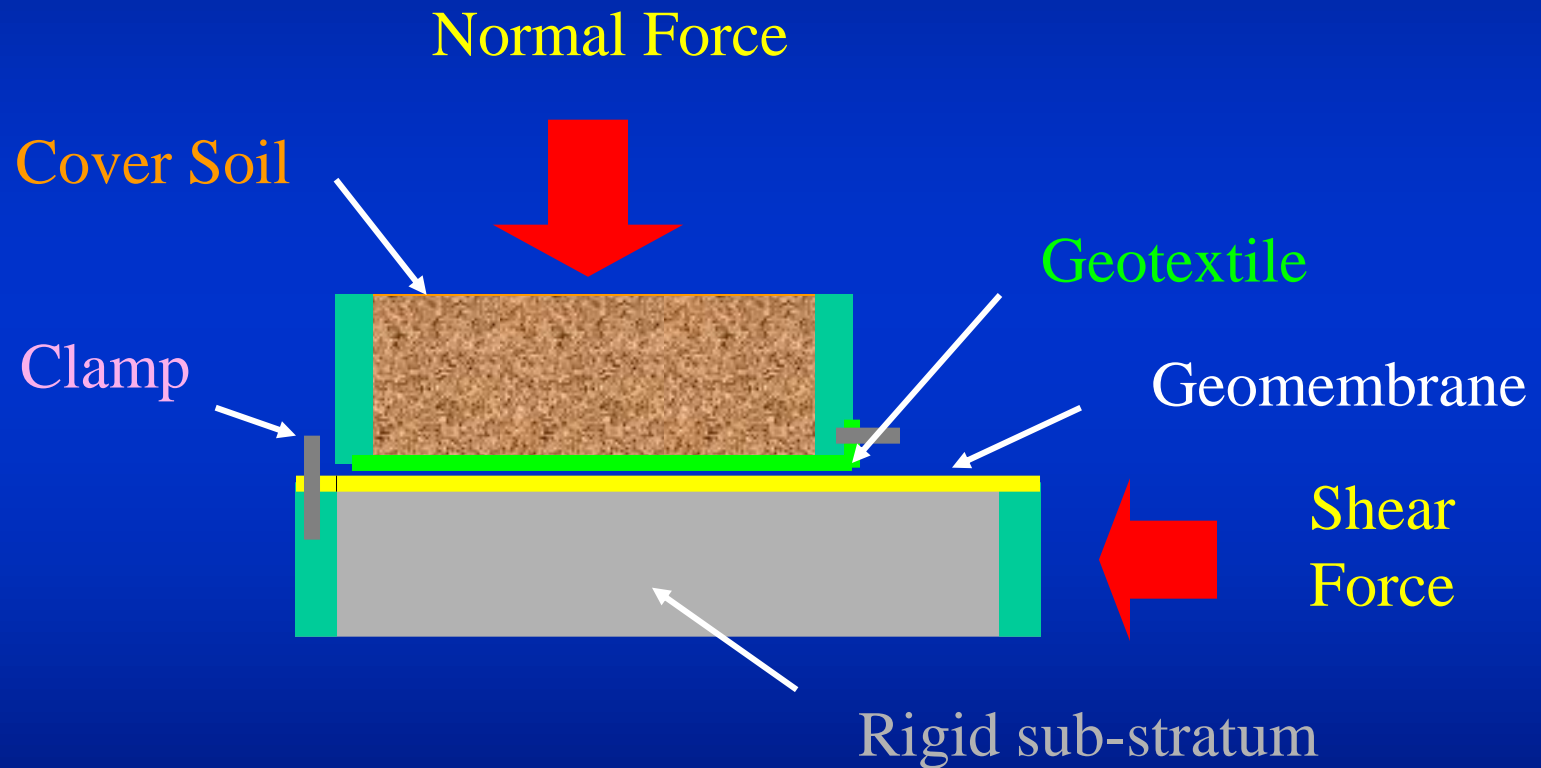

# Direct shear apparatus

(modified soil mechanics device: top box rotates)

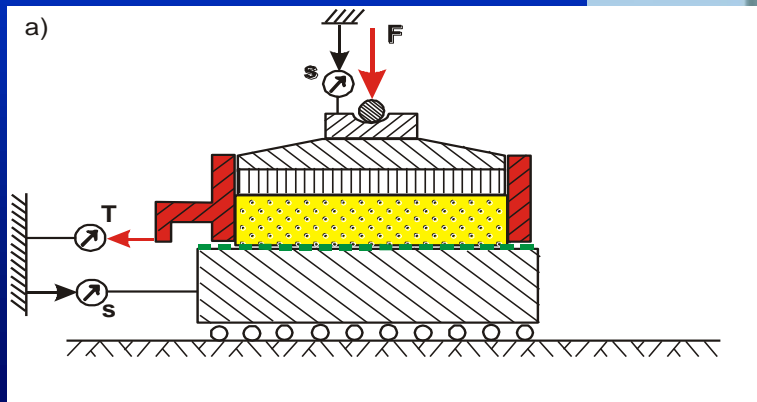



# Direct shear apparatus (designed for geosynthetics: fixed top box)

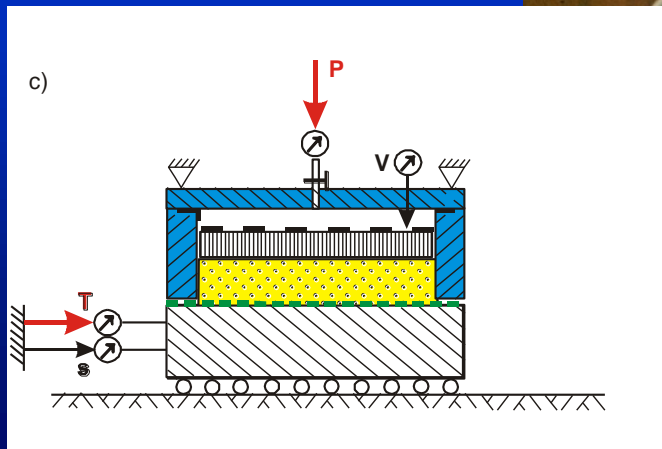
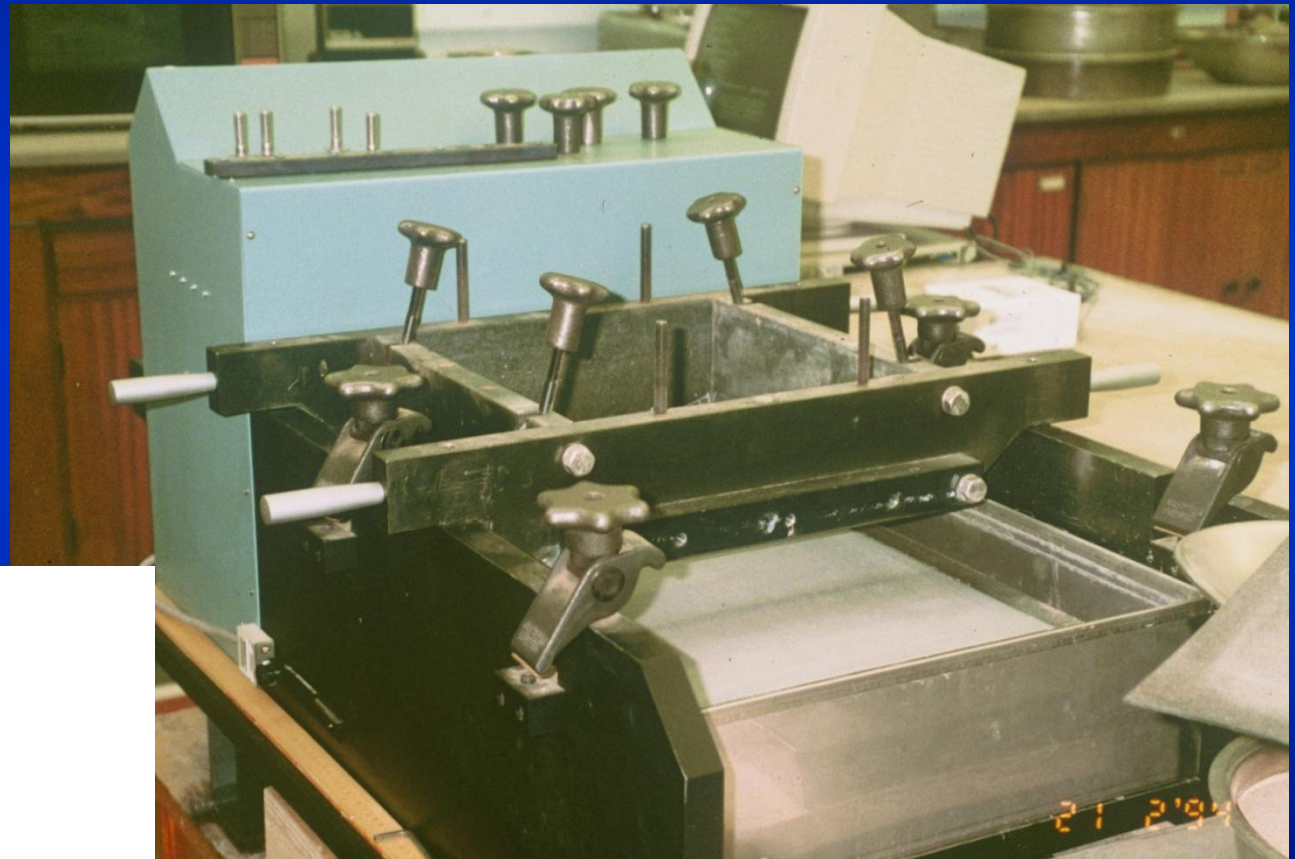

# Direct shear apparatus

(designed for geosynthetics: fixed top box)

Low normal stress system

Soil free  
to move in  
top box (!)

Top box  
fully  
fixed

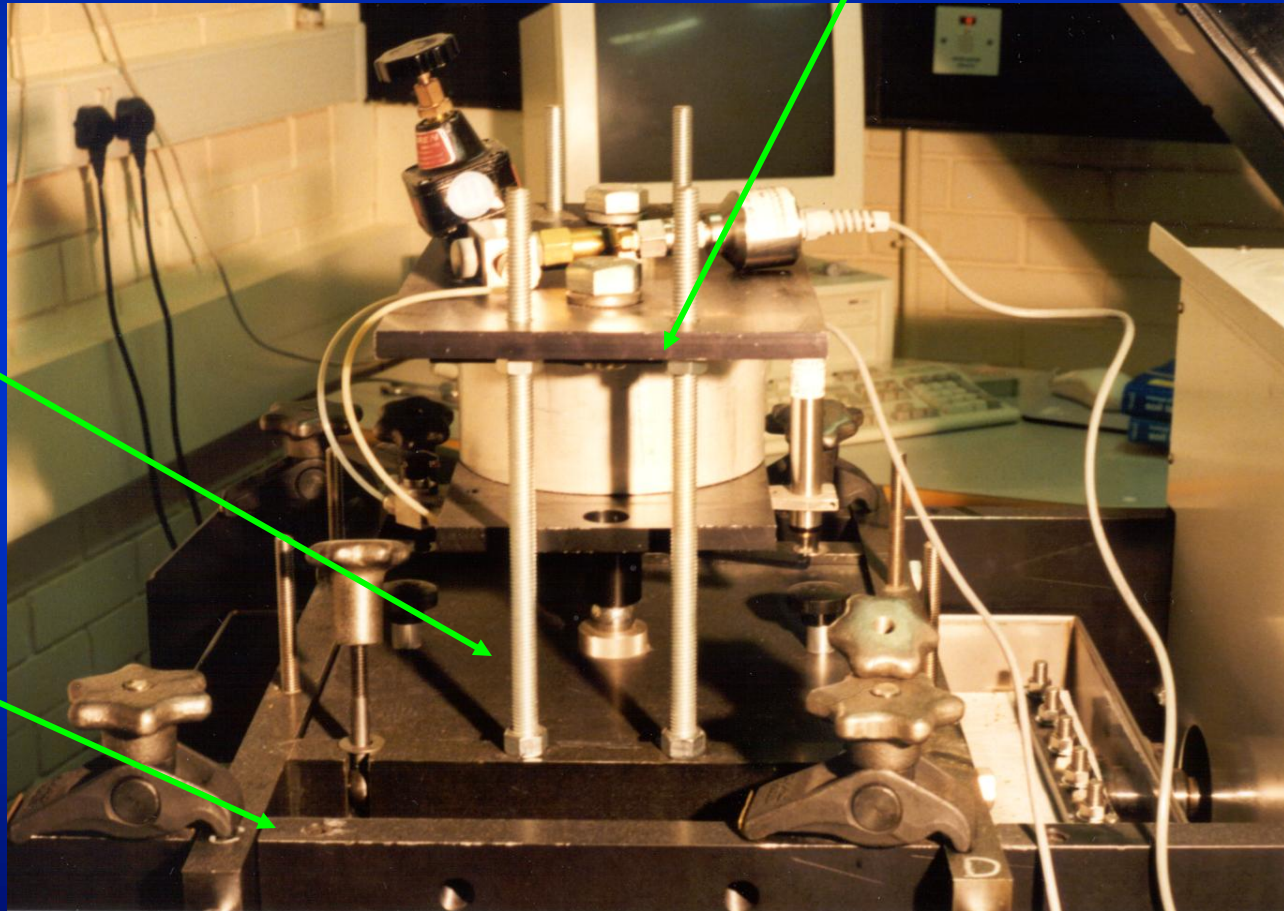

# Direct shear apparatus

(for geosynthetics: vertically moveable top box)

Top box  
can move  
vertically  
during  
shearing

Linear  
bearings to  
ensure no  
rotation of  
top box

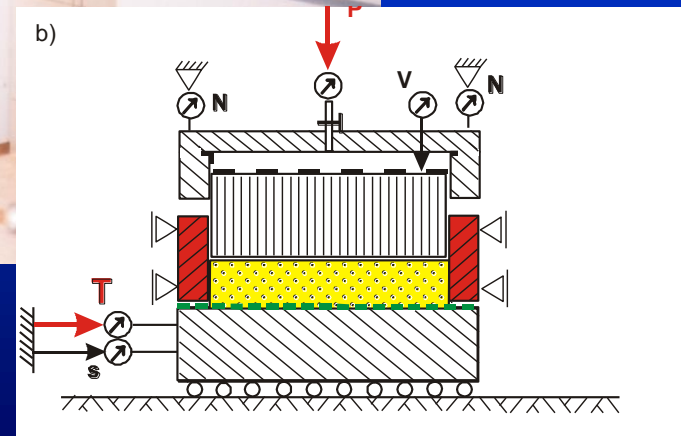
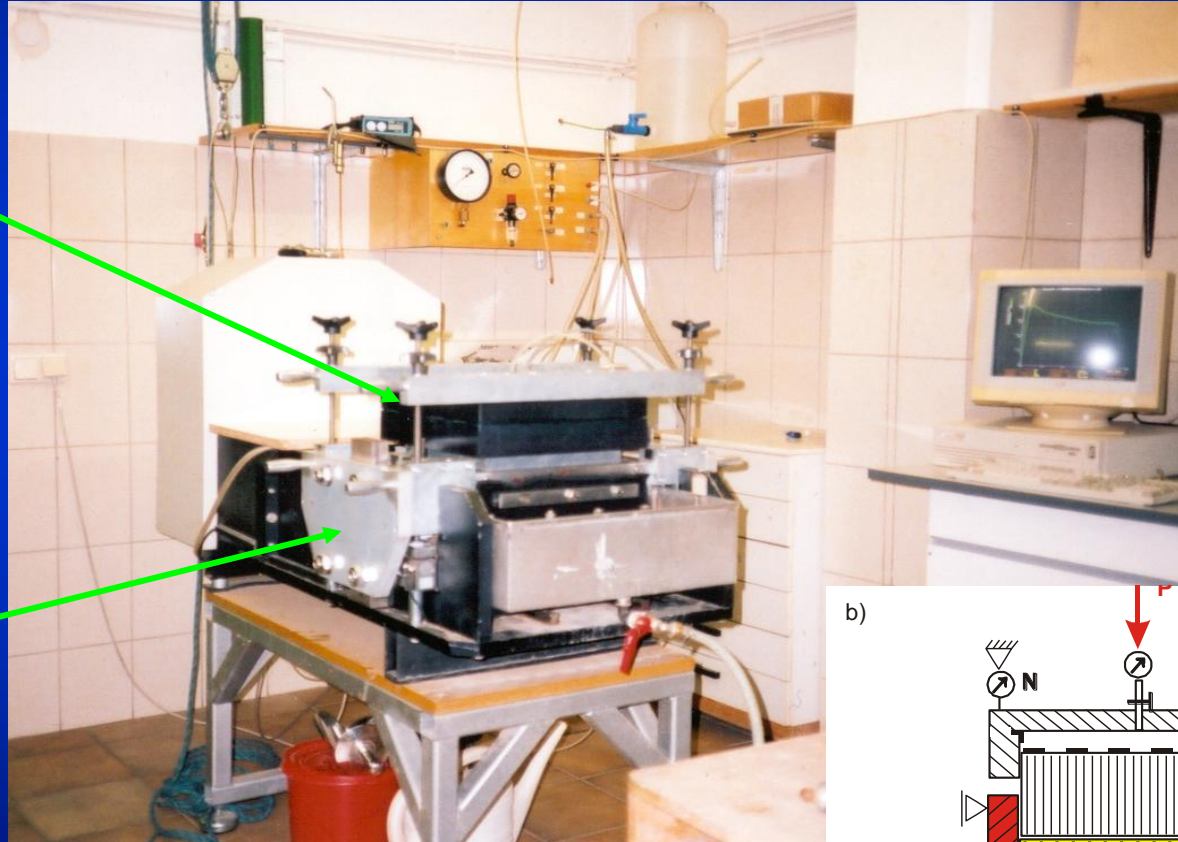

# Variation in normal stress

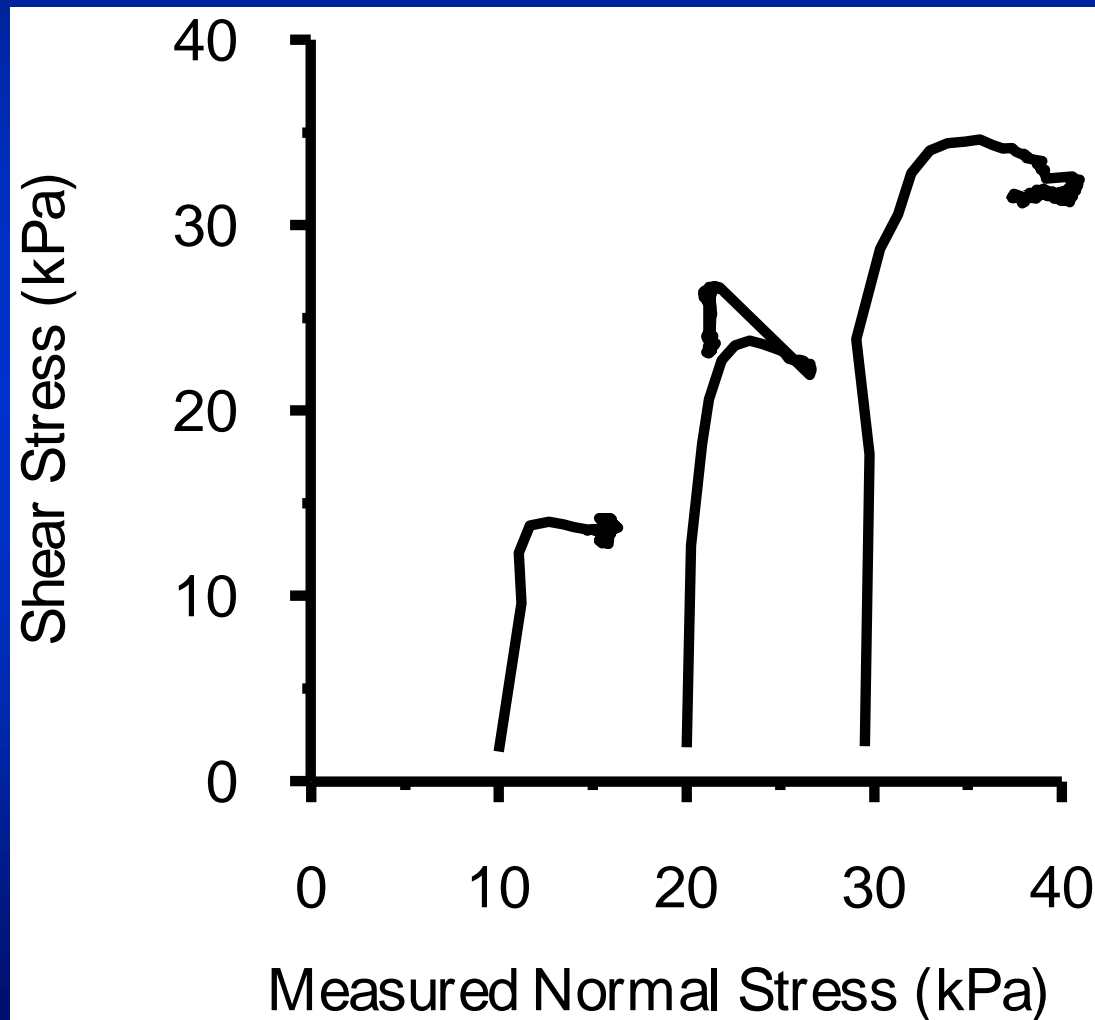

# DSA results: Smooth geomembrane vs. geotextile

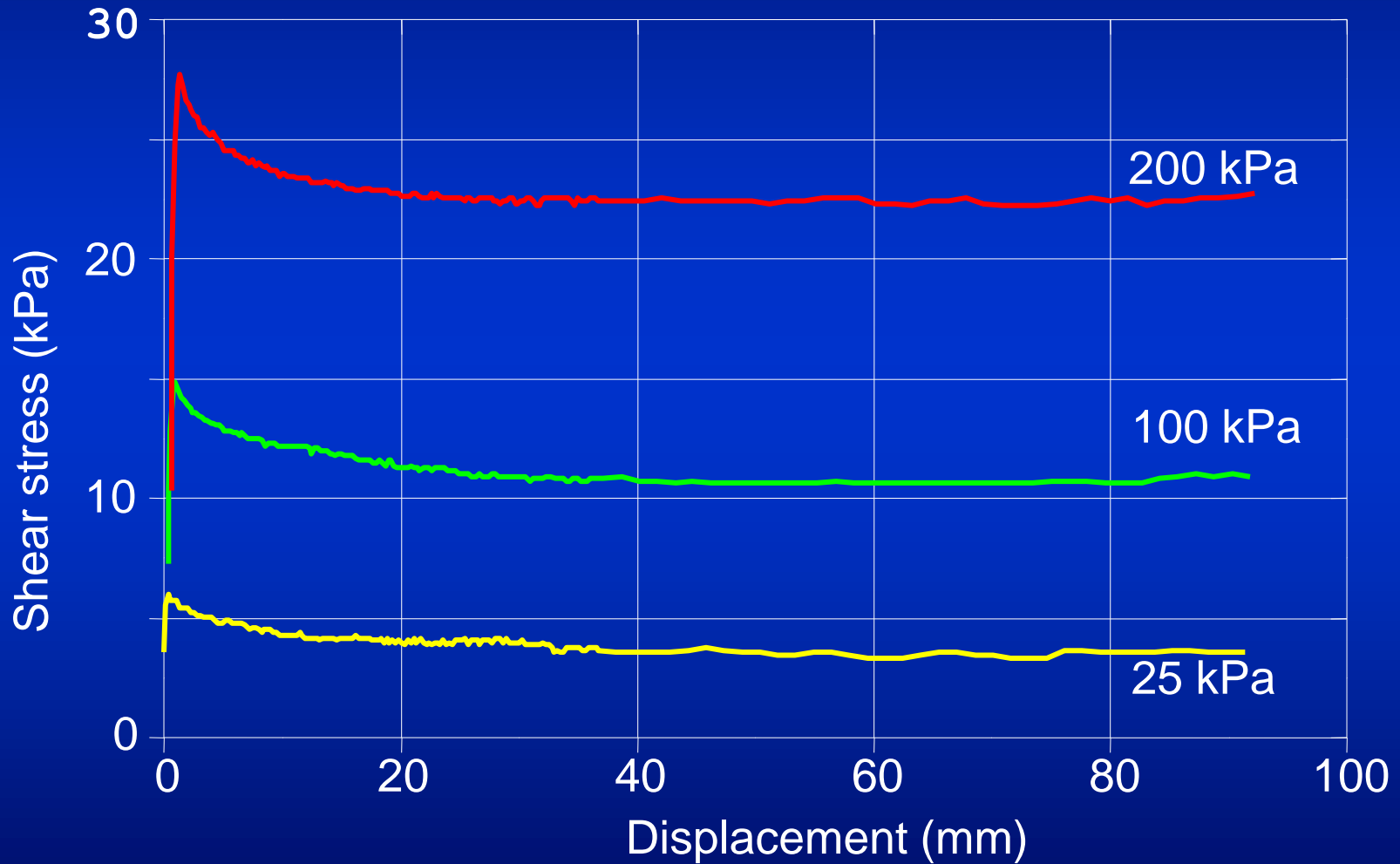

# DSA results: Textured geomembrane vs. geotextile

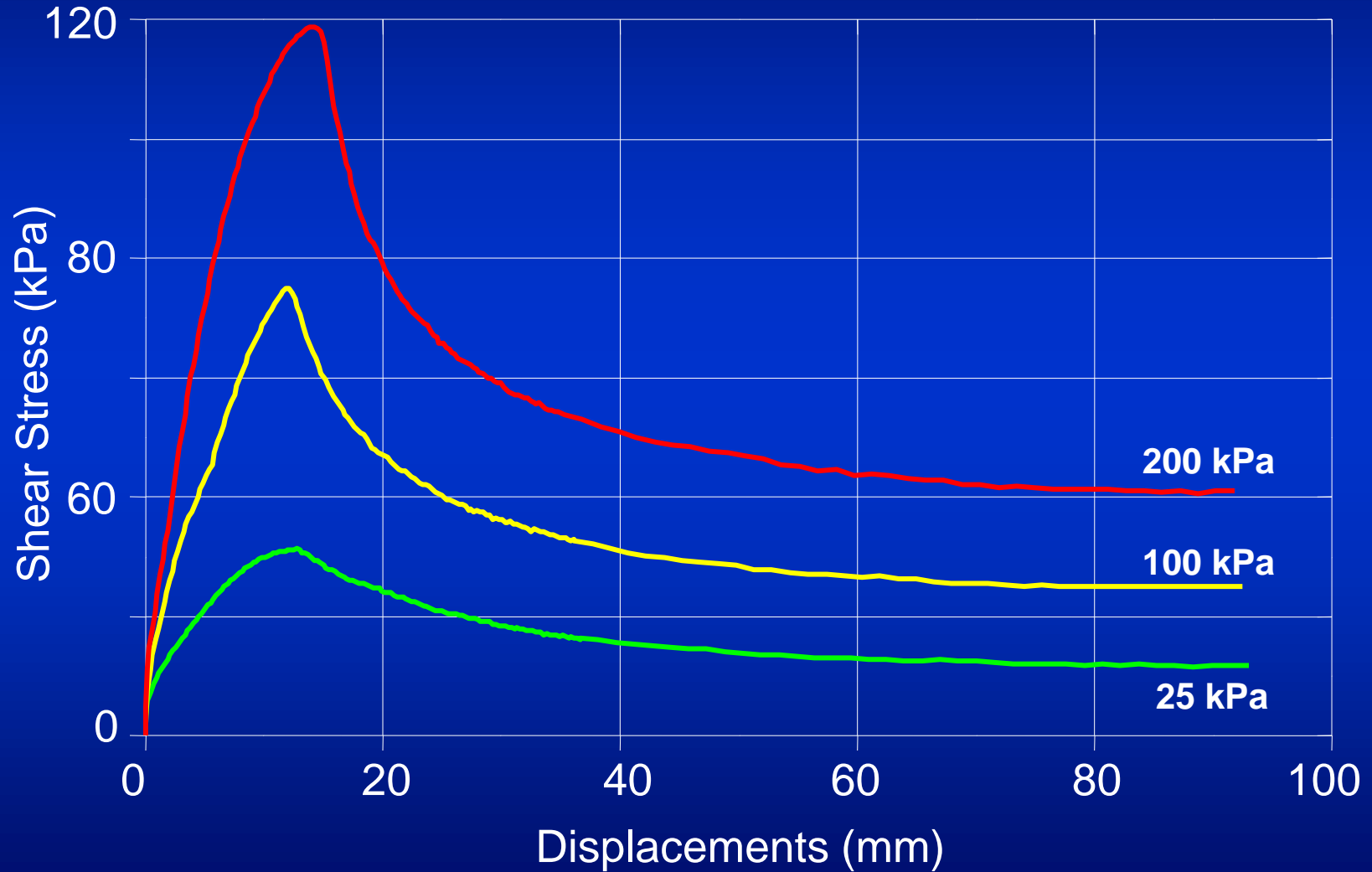

# Measurement: Tilting table apparatus

- No consensus of opinion as to what size should be used (box length is important)
- Only peak friction angle measured
- No shear stress/displacement information
- No residual friction angle
- Limited use (low normal stresses only)
- Relevant for veneer type problems

# Tilting table apparatus

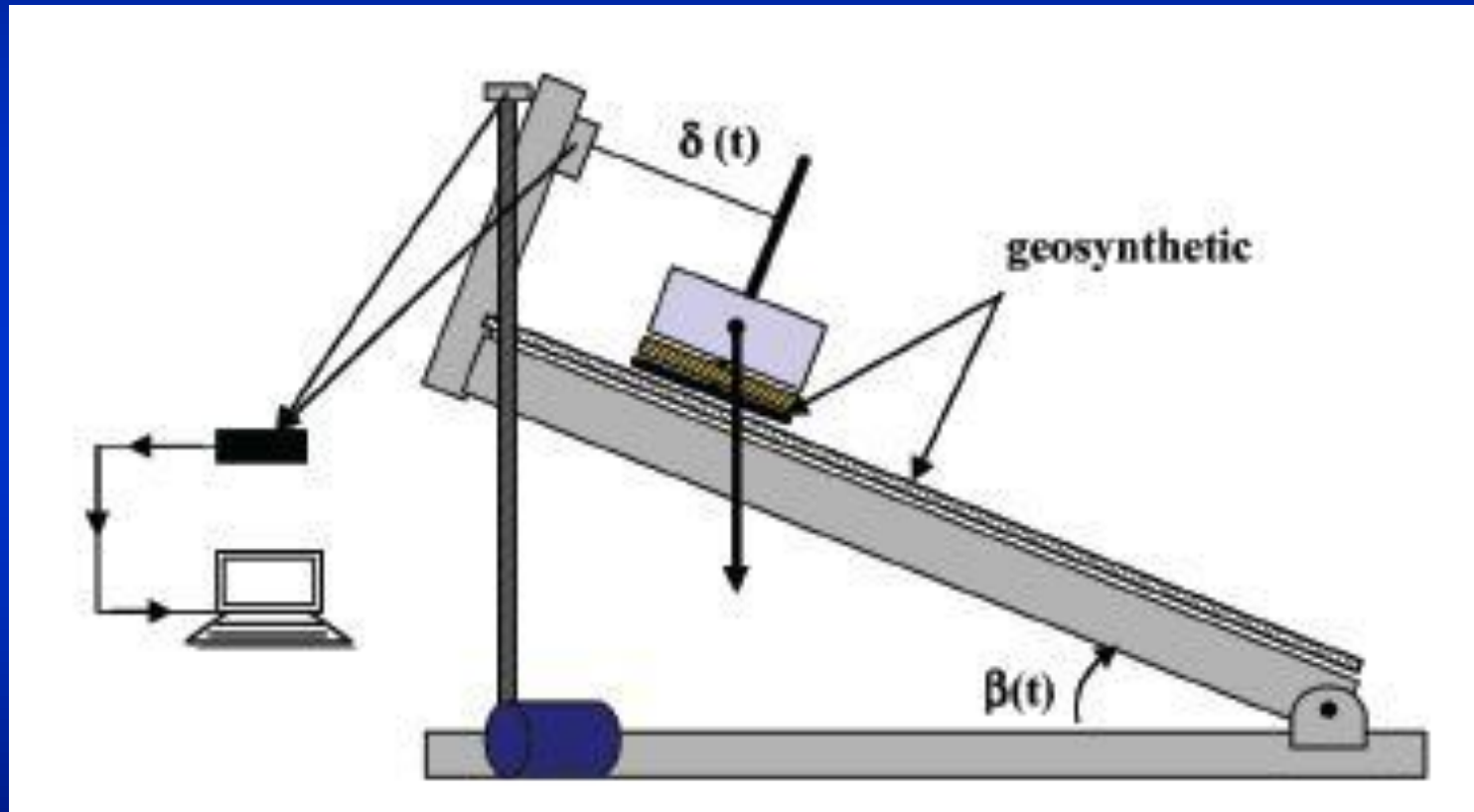

(Gourc et al. 2006)



# Tilting table apparatus



# Tilting table results

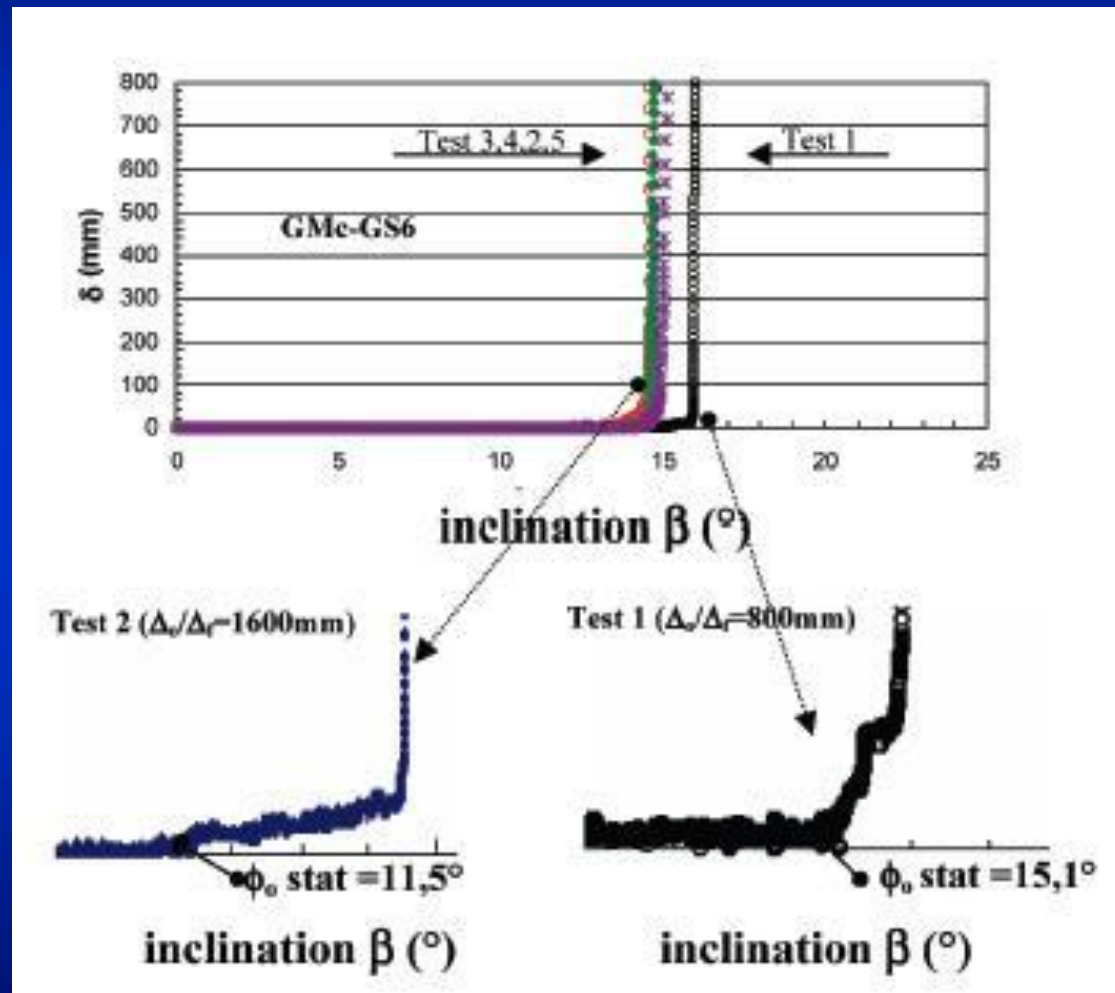

(Gourc et al. 2006)

# Ring shear apparatus (RSA)

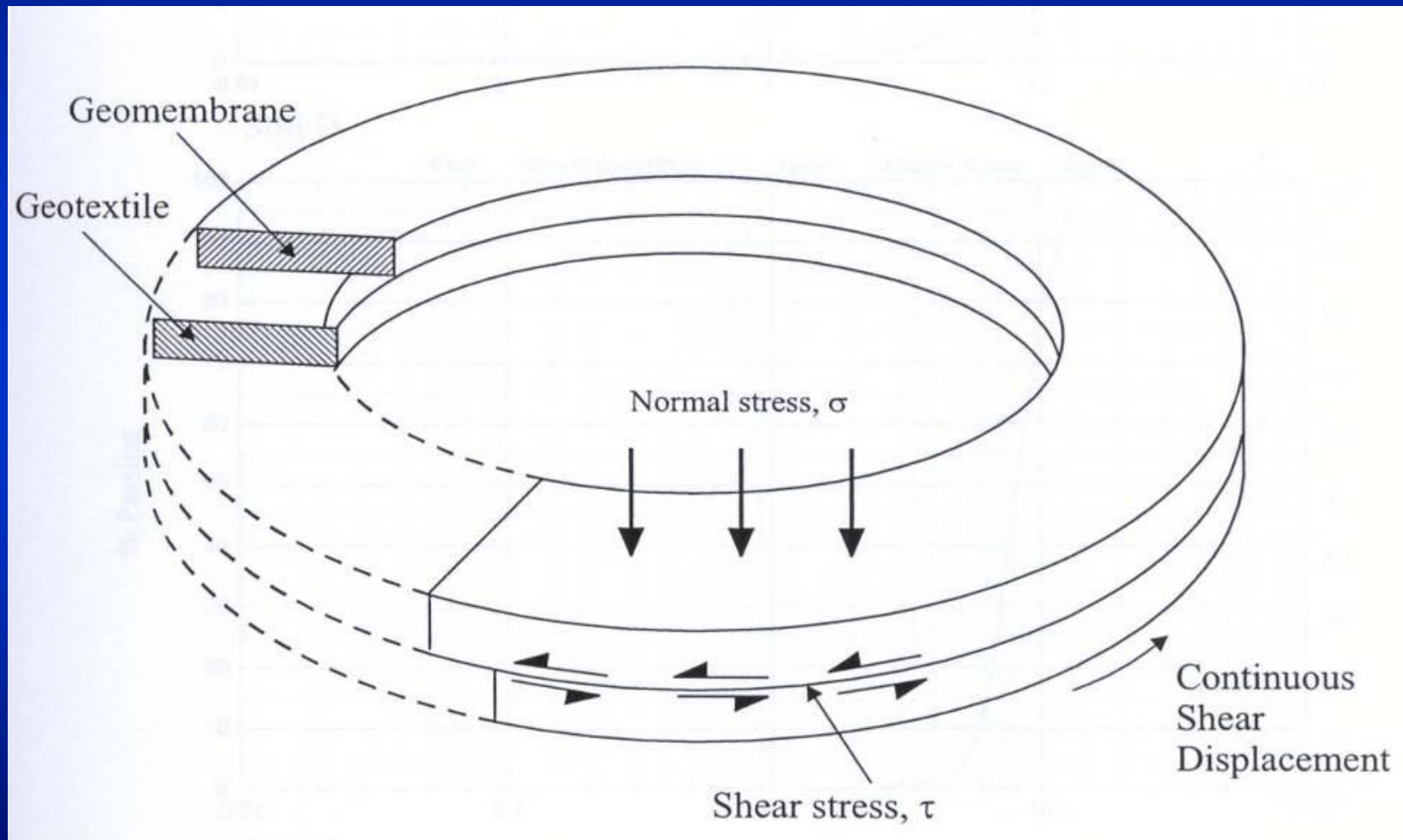

# Measurement: Ring shear apparatus

- Unlimited displacement - true residual shear strengths
- Full stress range can be accommodated
- Direction of shearing not comparable to field
- Peak shear strengths not reliable
- Cannot use granular materials or large geosynthetics

# Bromhead ring shear apparatus

Rotational shear between upper and lower annular samples of geosynthetic

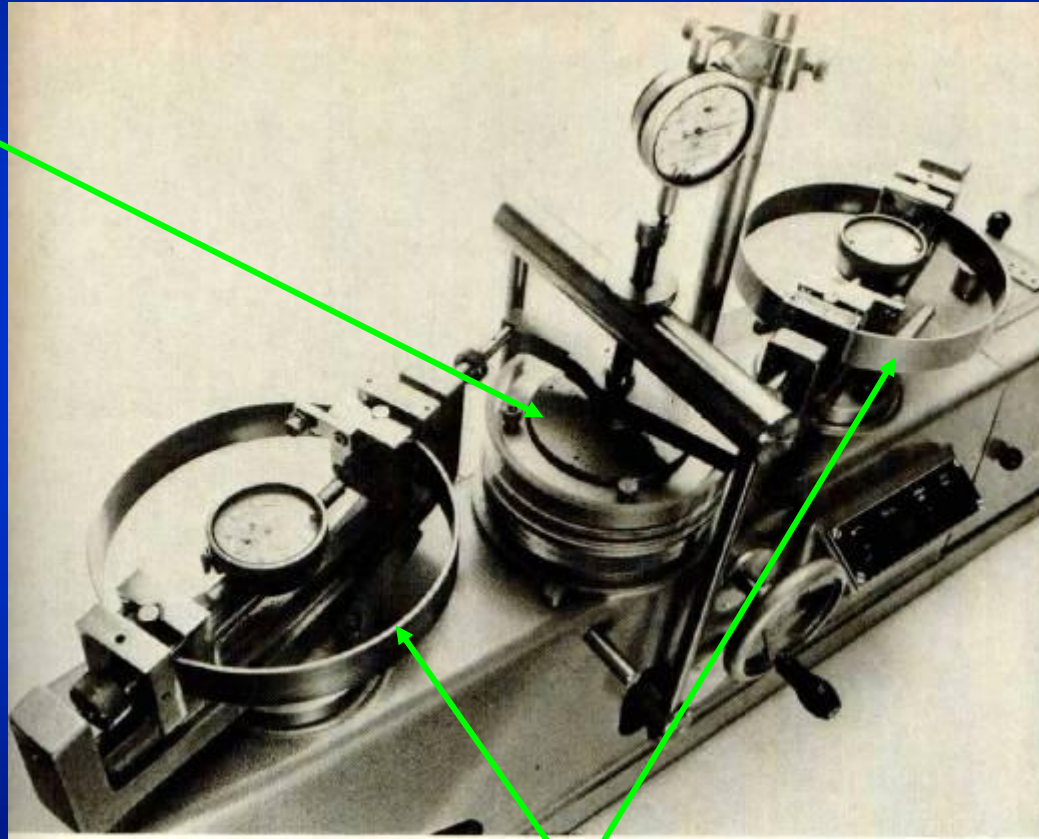

Matched proving rings

# Residual strength measured using RSA

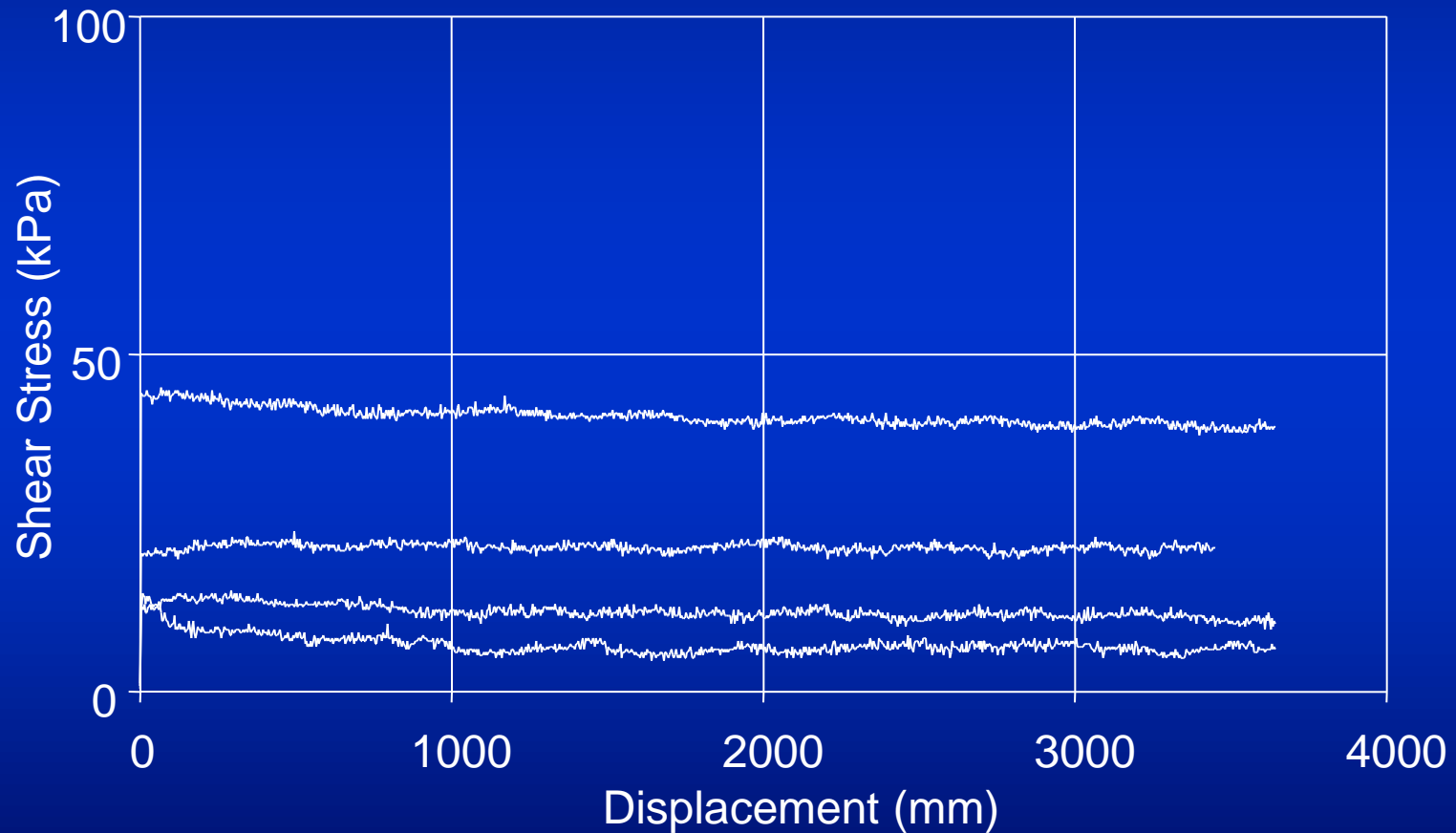

# Residual shear strength: Comparison of DSA and RSA test methods

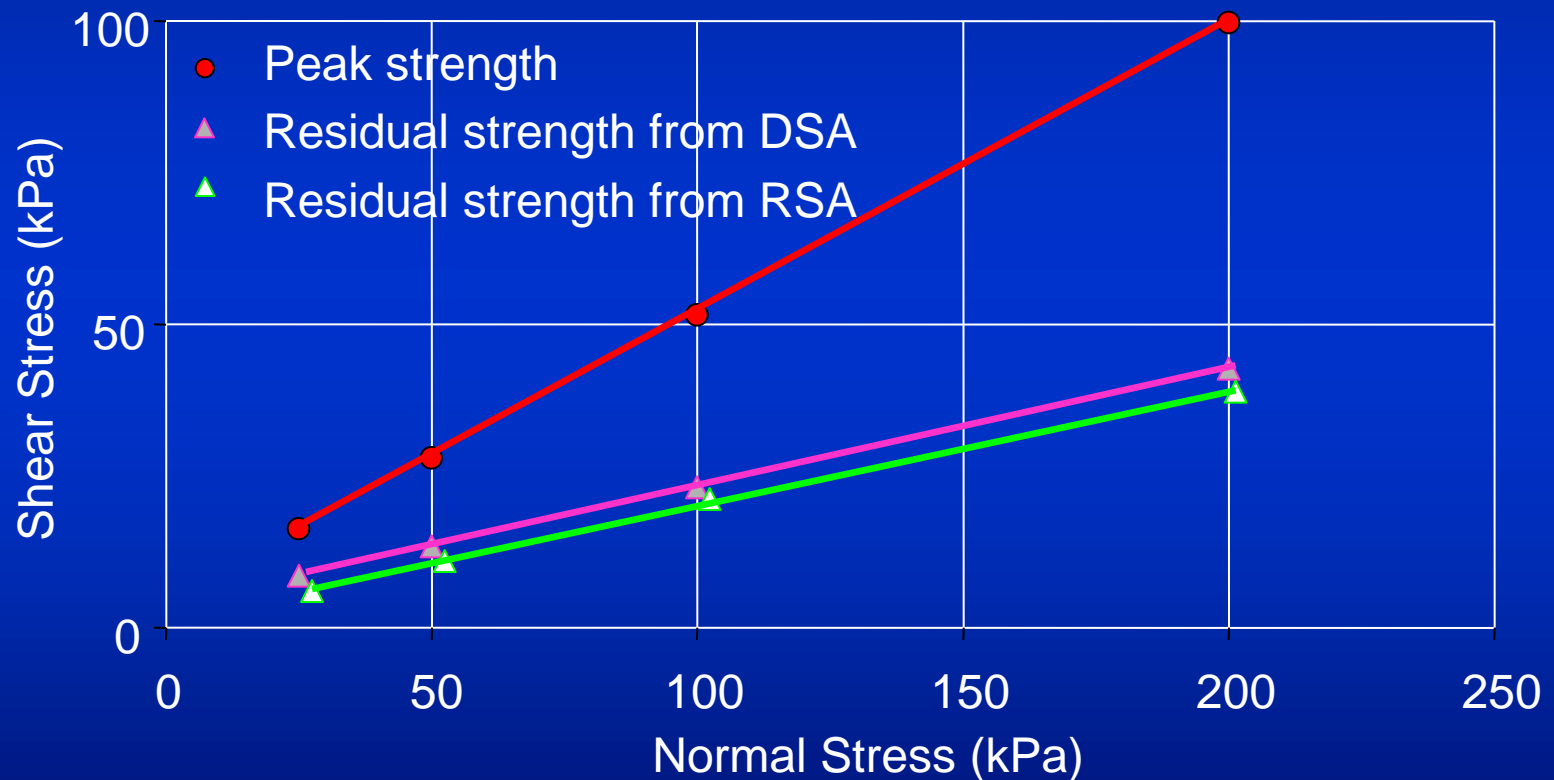

# Factors influencing interface behaviour



# Test standards

- ASTM D5321.08 - Performance testing for soil vs. geosynthetic and geosynthetic vs. geosynthetic interfaces (**comprehensive guidance**)
- BS 6906:1991 – Covers mainly index tests for sand and geosynthetic interfaces (**out of date**)
- BS EN ISO 12957-1:2005 - Index tests only for sand vs. geosynthetic (**no use for design**)
- GDA E3-8 is specifically devoted to landfill design (**only in German**)
- A comparison of specifications is provided in Dixon (2010)

# Key factors influencing measured behaviour

- Design of direct shear device....
- Test set up (e.g. method of clamping/restraining the geosynthetic, gap size between top and bottom boxes, dry or submerged conditions, material in top box used to transmit normal stress to interface, shearing rate, temperature, normal stress range....)
- Variability of materials, direction of shearing, number of tests....
- **SOIL MECHANICS !** (density, maximum particle size, consolidation, drained or undrained shearing, pore water pressures, volume changes....)

# Textured geomembrane vs. geotextile: Dry tests

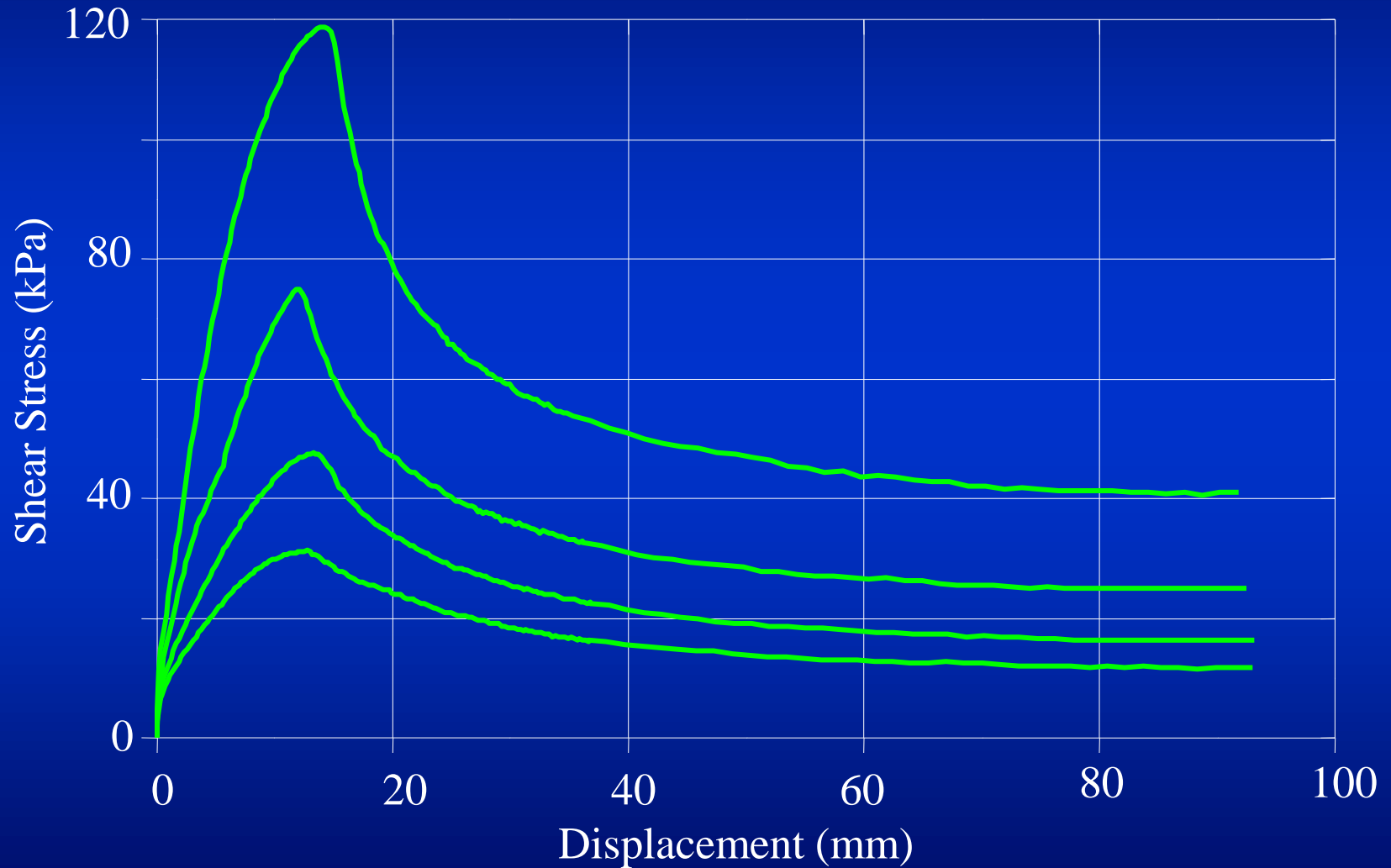

# Textured geomembrane vs. geotextile: Dry and Submerged Tests

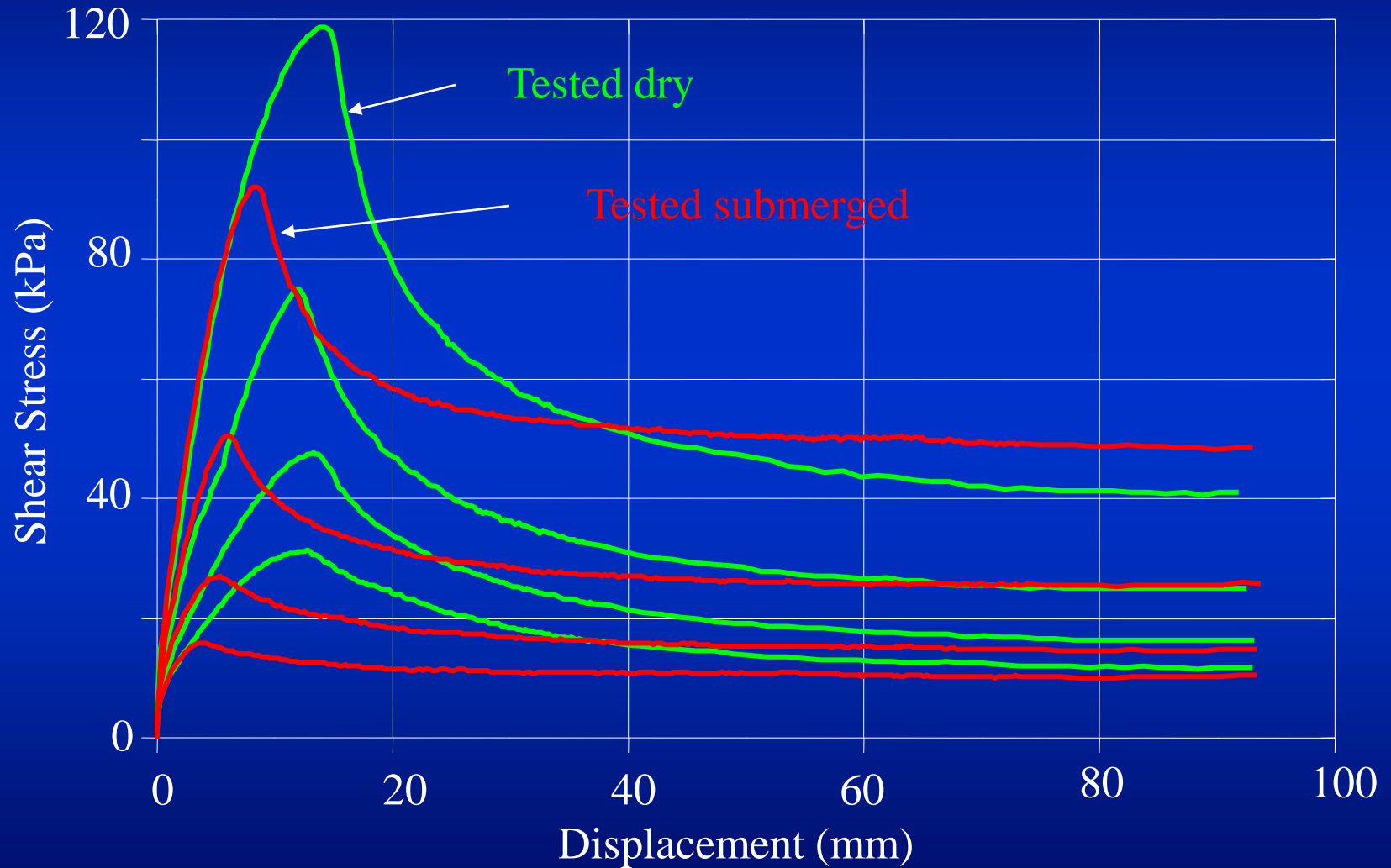

# Smooth geomembrane vs. geotextile: Dry tests

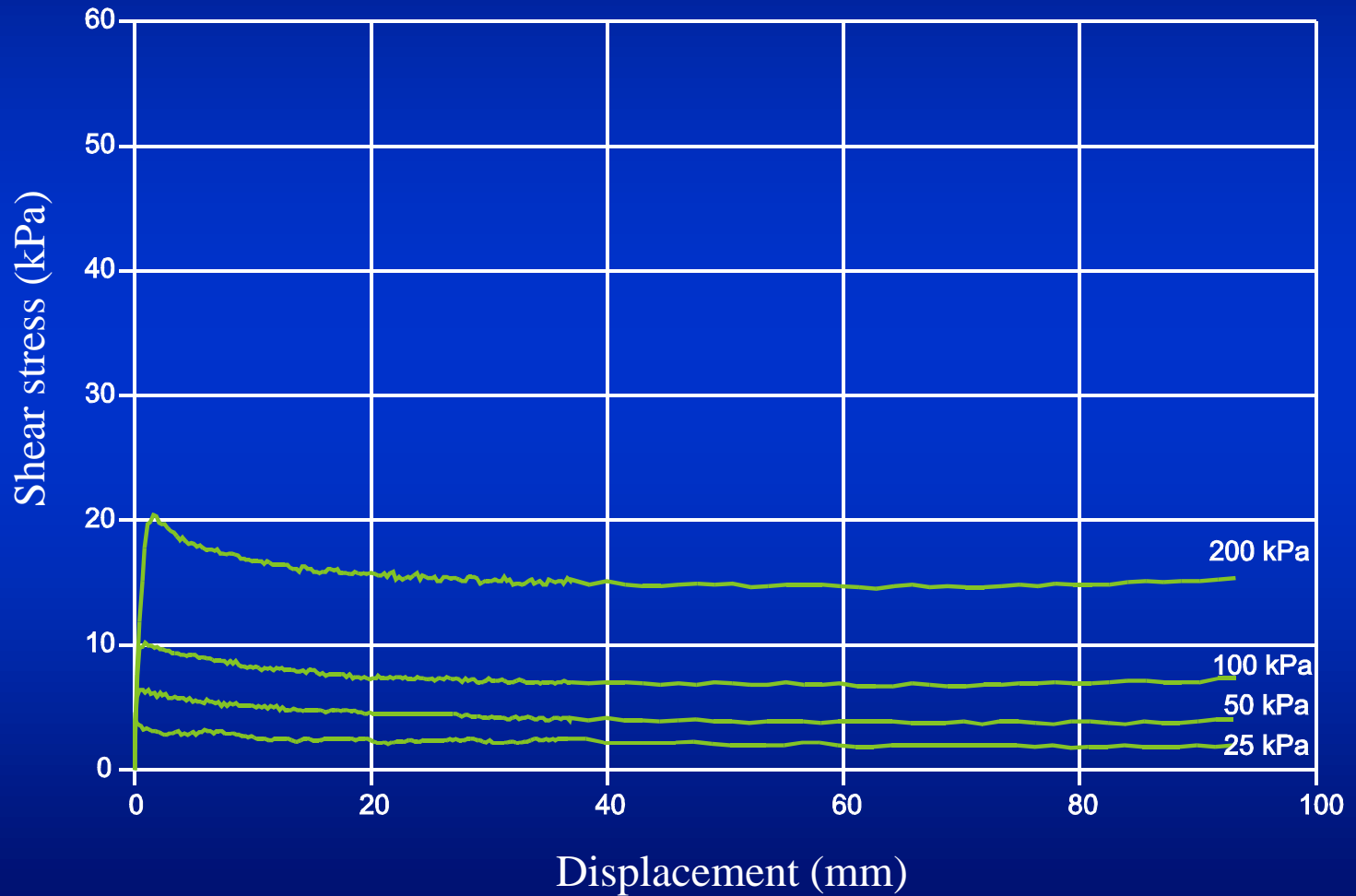

# Smooth geomembrane vs. geotextile: Dry and submerged tests

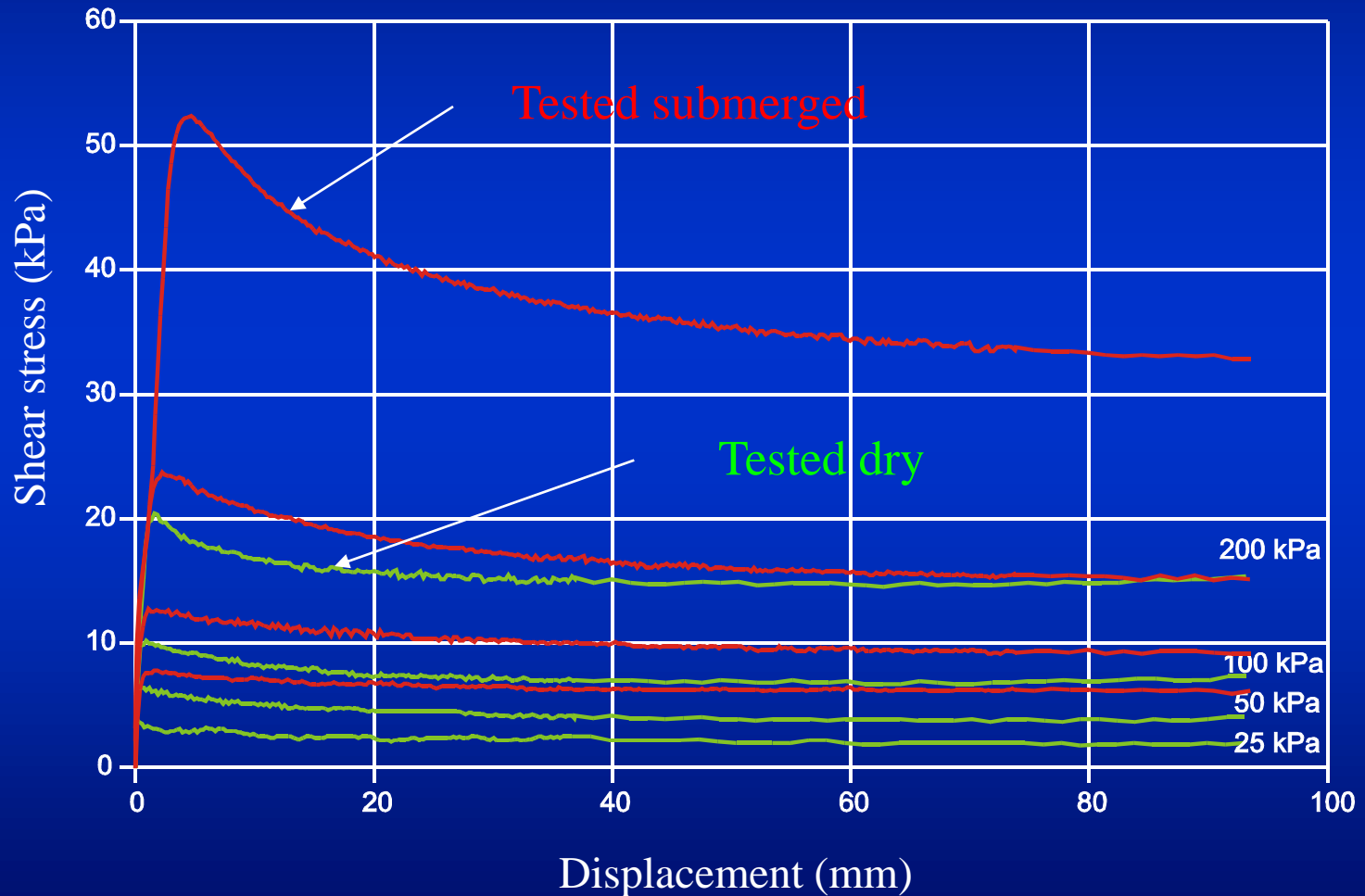

# Influence of cover soil on measured geotextile vs. drainage core shear strength

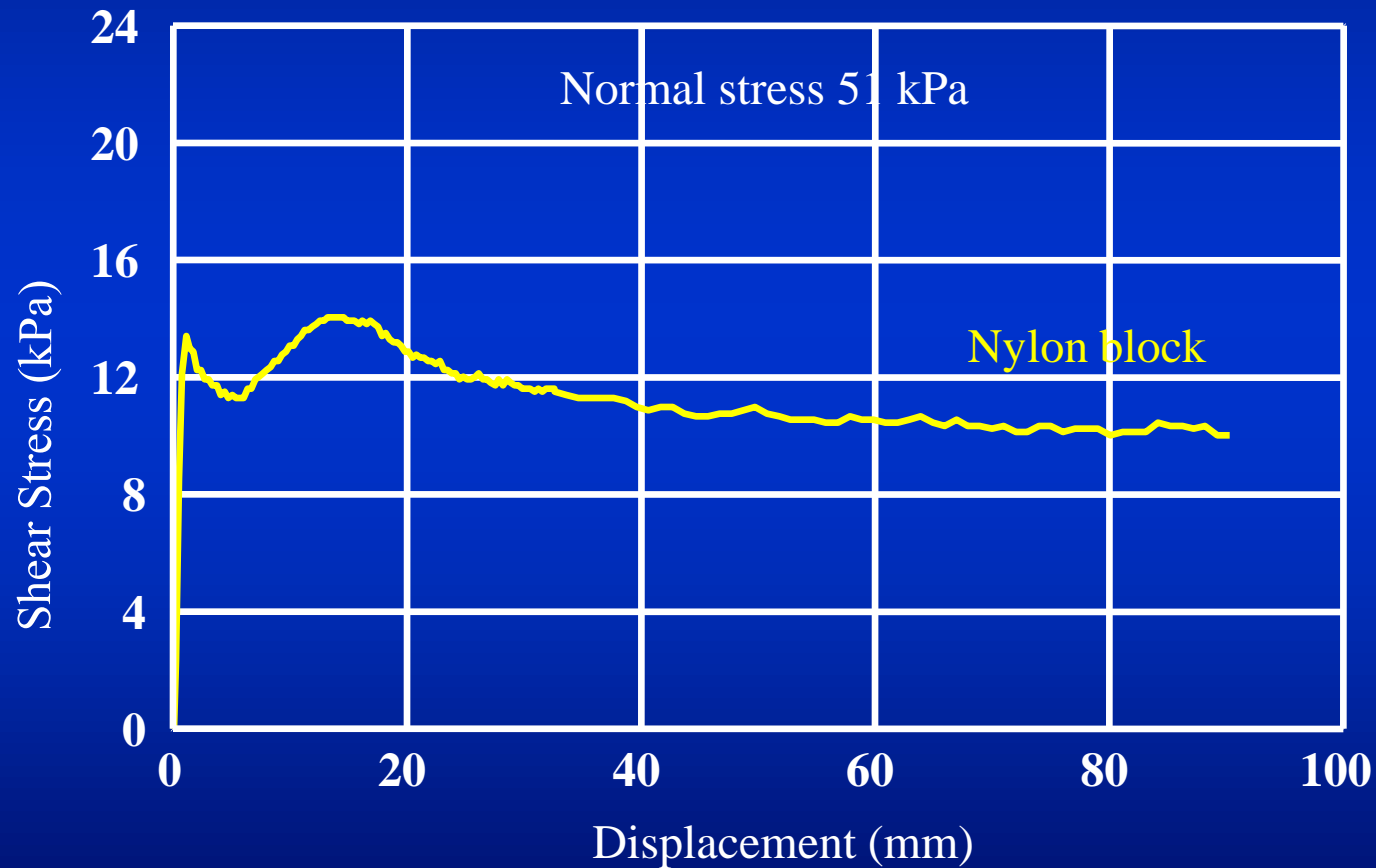

# Influence of cover soil on measured geotextile vs. drainage core shear strength

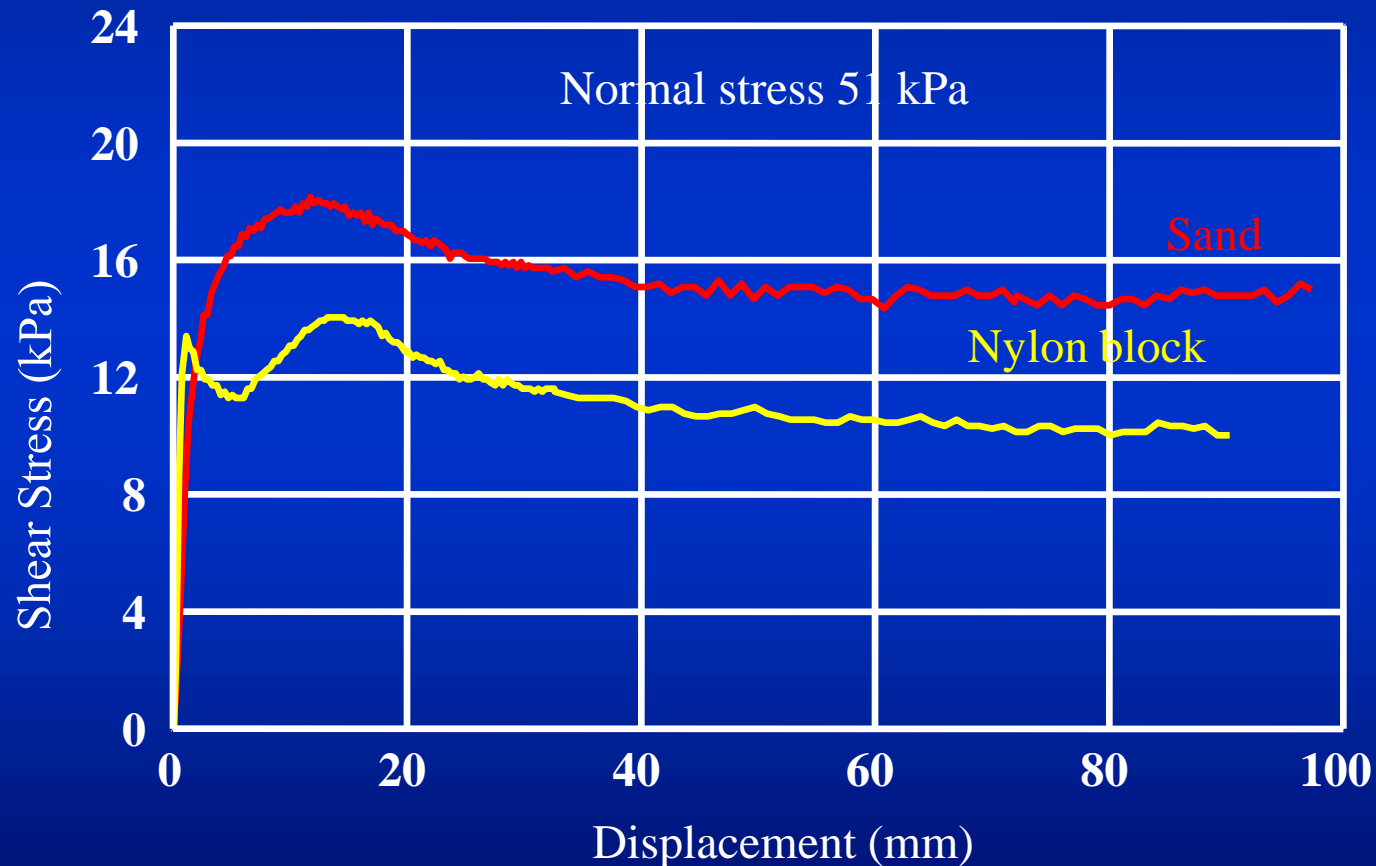



# Influence of cover soil on measured geotextile vs. drainage core shear strength

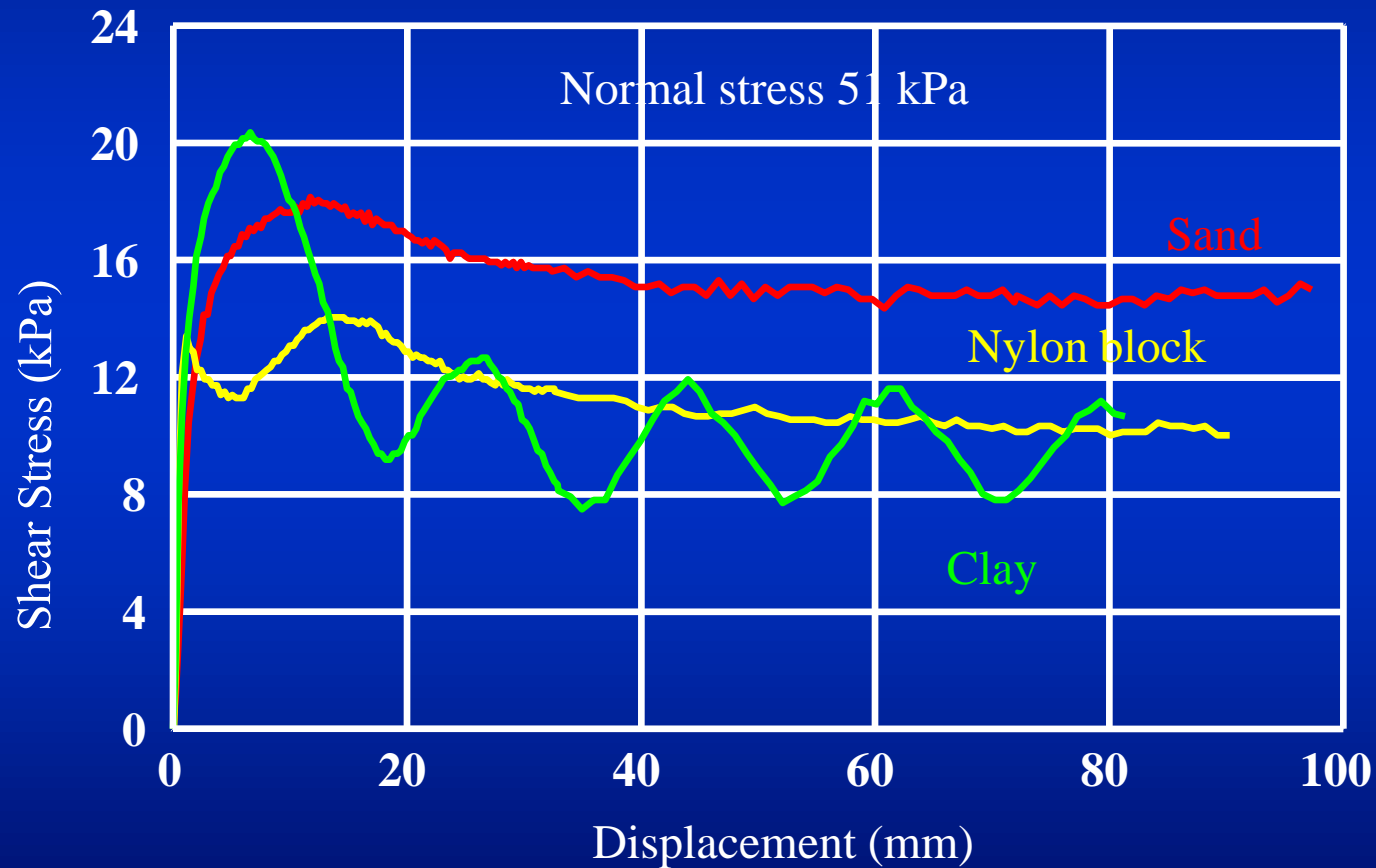

# Measurement of internal interface shear strength of a geocomposite material

Cusped rigid central core clamped to bottom box

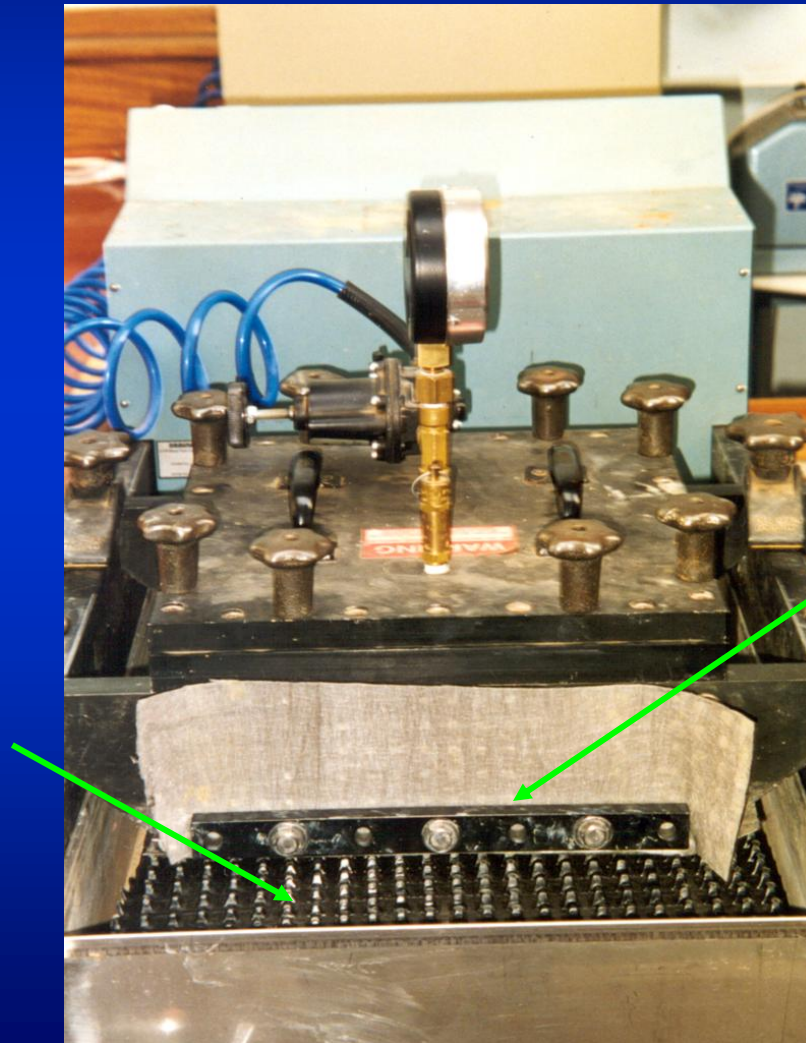

Heat bonded geotextile glued to central core and clamped to top box

# Measurement of internal interface shear strength of a geocomposite material

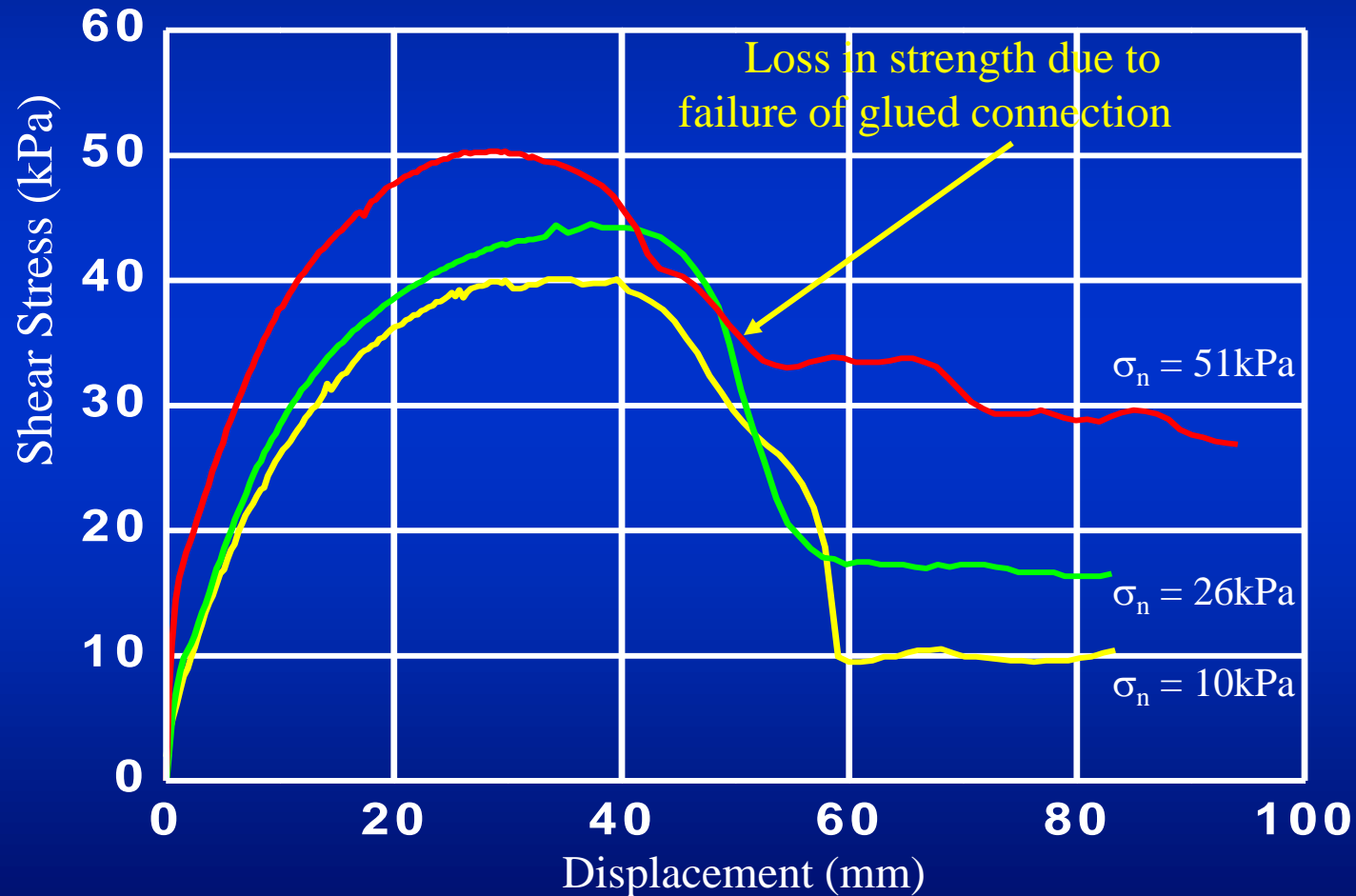

# Geotextile vs. glued core: Peak and residual strength envelopes

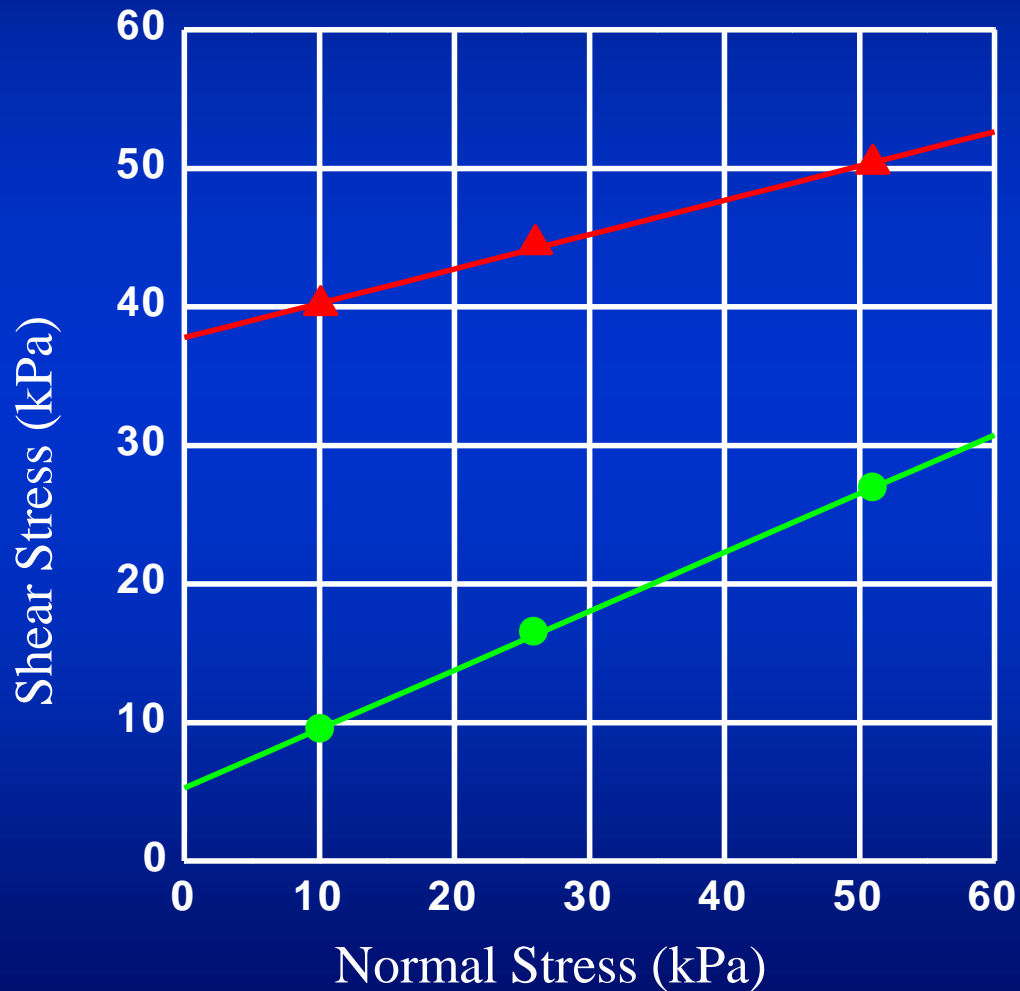

Strength parameters

Peak

$$\alpha_p = 38 \text{ kPa}$$

$$\delta_p = 14^\circ$$

Residual

$$\alpha_r = 5 \text{ kPa}$$

$$\delta_r = 23^\circ$$

# Peak and residual best fit straight line failure envelopes

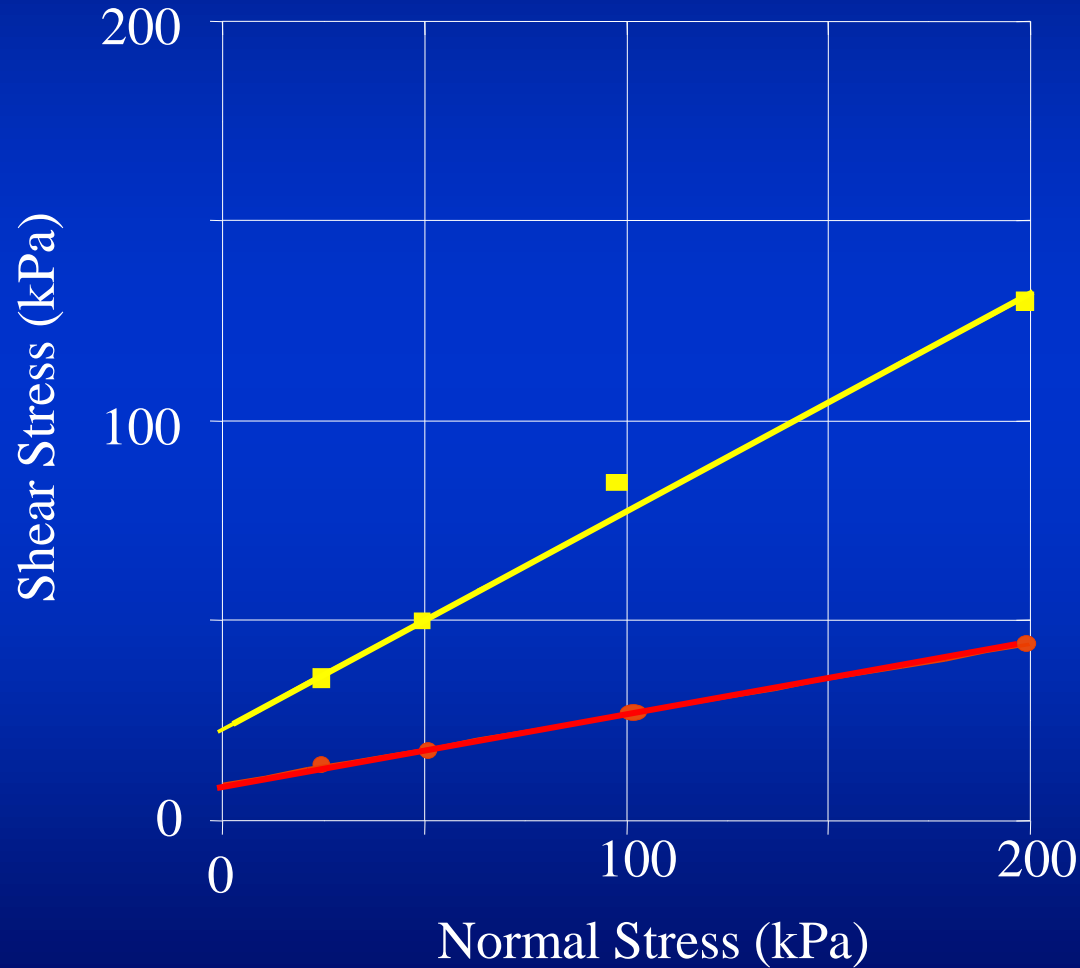

# Peak strength best fit second order polynomial

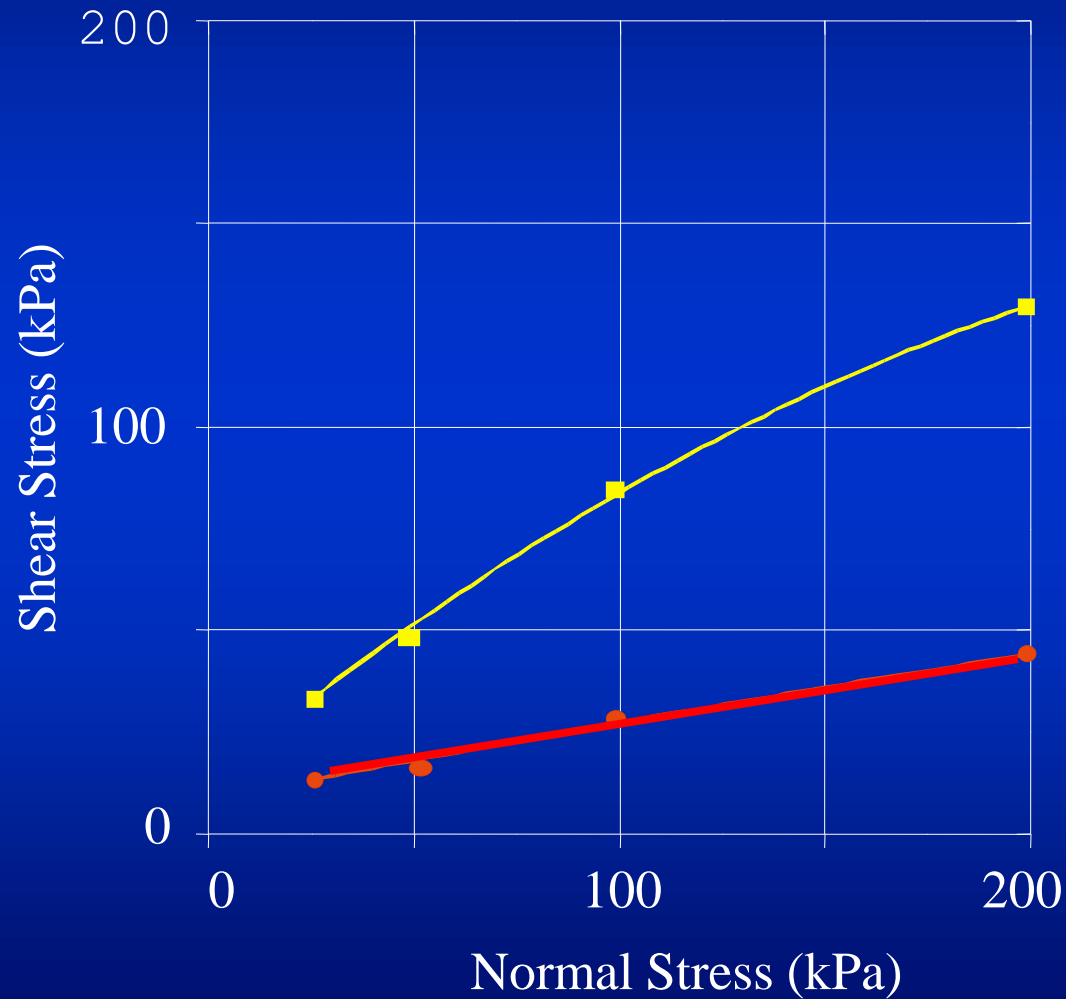

# Peak strength extrapolation from height to low normal stresses

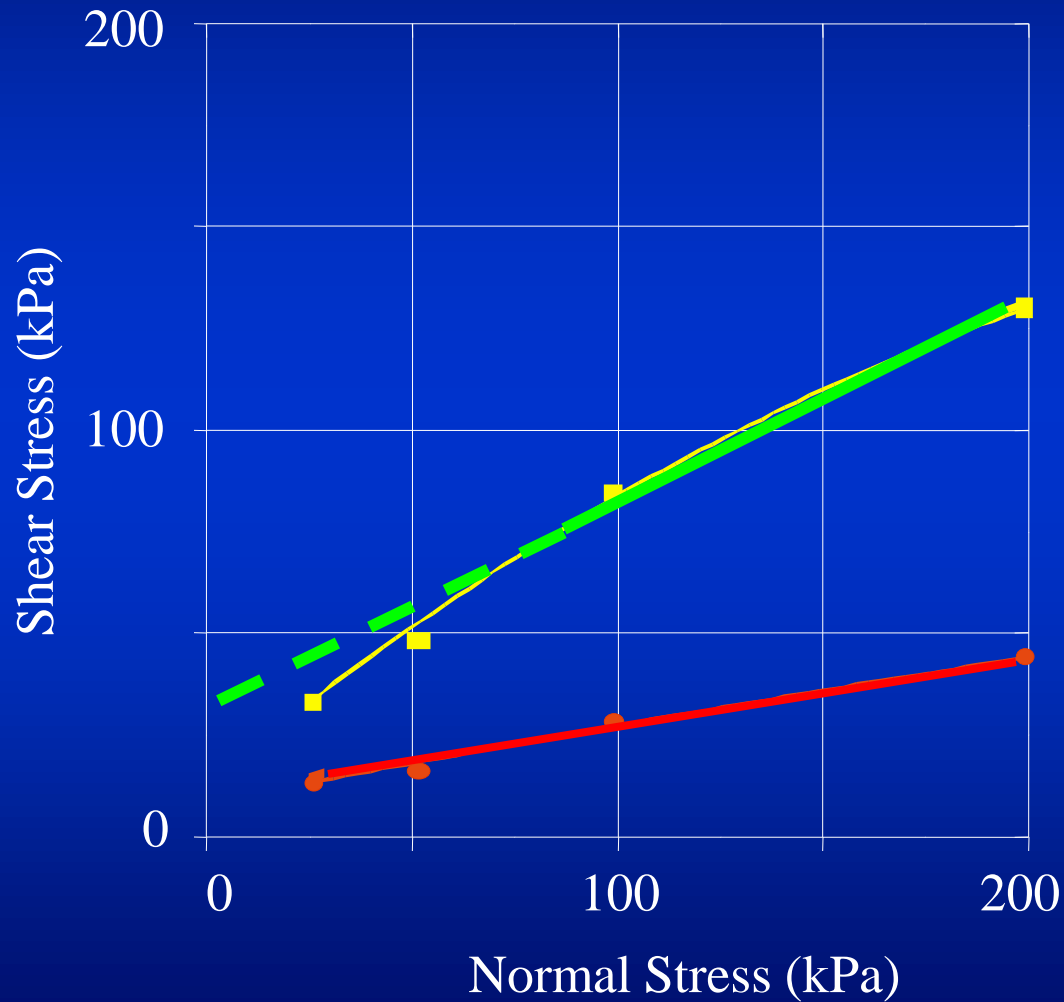

Inappropriate use of tests at high normal stresses for a low normal stress problem e.g . cover design

# Should adhesion ( $\alpha$ ) values be used (1) ?

The following conditions can produce an 'adhesion' value:

- An interface with a shear strength at zero normal stress e.g. textured geomembrane/non-woven geotextile (use the  $\alpha$  value in design)
- A best fit straight line through data forming a curved failure envelope (use the  $\alpha$  value in design if the tests were carried out over an appropriate normal stress range)



# Should adhesion ( $\alpha$ ) values be used (2) ?

- Incorrect measurement of shear strength resulting from the design and/or operation of the test equipment e.g. fixed top box
- Best fit straight line located through a limited number of data points with scatter about the mean value for each normal stress (use  $\alpha$  values in design with care)

Which parameters should be  
used in design?  
(peak, residual or  
somewhere in between)

# Mechanisms resulting in post-peak reductions in strength (1)

- Wear of geosynthetic/geosynthetic interfaces
  - Combing of fibres destroying Velcro® effect
  - Polishing of surfaces and reduction/removal of asperities (roughening and ploughing of the surface can result in increased interface strength)
- Soil/geosynthetic interfaces can also suffer from the above mechanisms of wear, plus the following:
  - Dilatency of soil in the shear zone
  - Realignment of clay particles parallel to the interface

# Mechanisms resulting in post-peak reductions in strength (2)

- Loss of internal shear strength in geocomposites and GCL
  - Failure of needle punched fibres, stitching and glued connections
- All these mechanisms require relative shear displacement of the two materials forming the interface
- Changes that occur with no relative displacement may result in changes to both peak and residual strengths
  - Changes in soil density and moisture content
  - Extrusion of bentonite from a GCL
  - Temperature change

# Mobilising post-peak strengths

- Construction related:
  - Dragging geosynthetics to position them
  - Construction plant loads during placement of veneer soil layers on slopes
  - Compaction of fine grained soils above geosynthetics
  - Improper storage and handling
- Landfill operation related:
  - Placement of waste on side slopes (same as soil veneers)
  - Settlement of waste adjacent to interface
  - Differential settlement of sub-grade

# Use peak or residual strength?

The answer is site specific:

- Consider all possible mechanisms and fully justify the approach taken
- Relate the selected parameters to the factor of safety required
- Consider both stability and integrity
- Even if global instability does not occur it is possible to have large relative displacements between lining components (**integrity failure**) which could lead to loss of continuity and hence function (protection, drainage)

# Development of post peak shear strength: Veneer slope

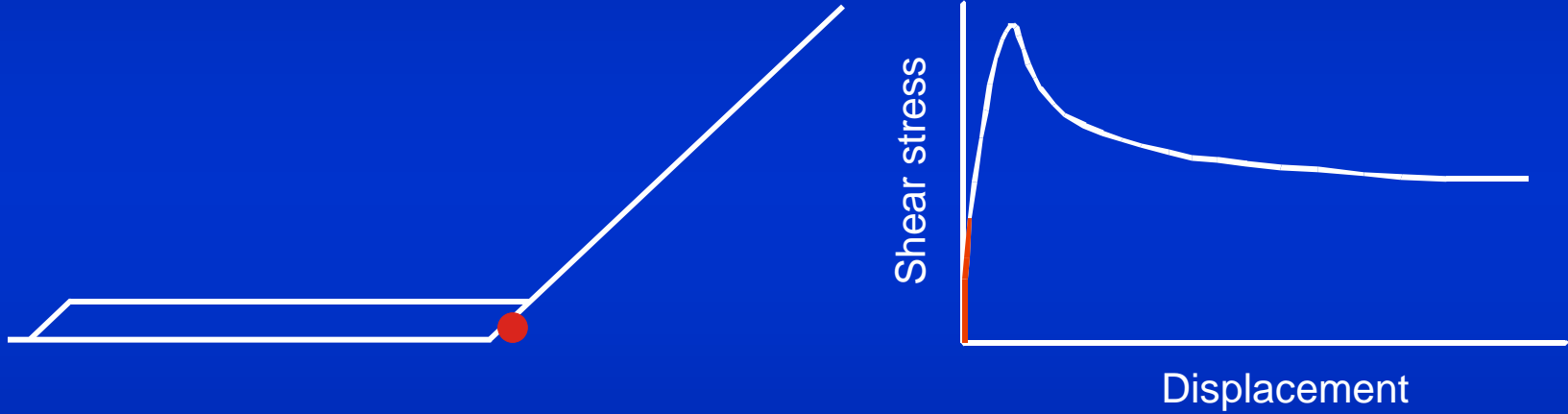

# Development of post peak shear strength: Veneer slope

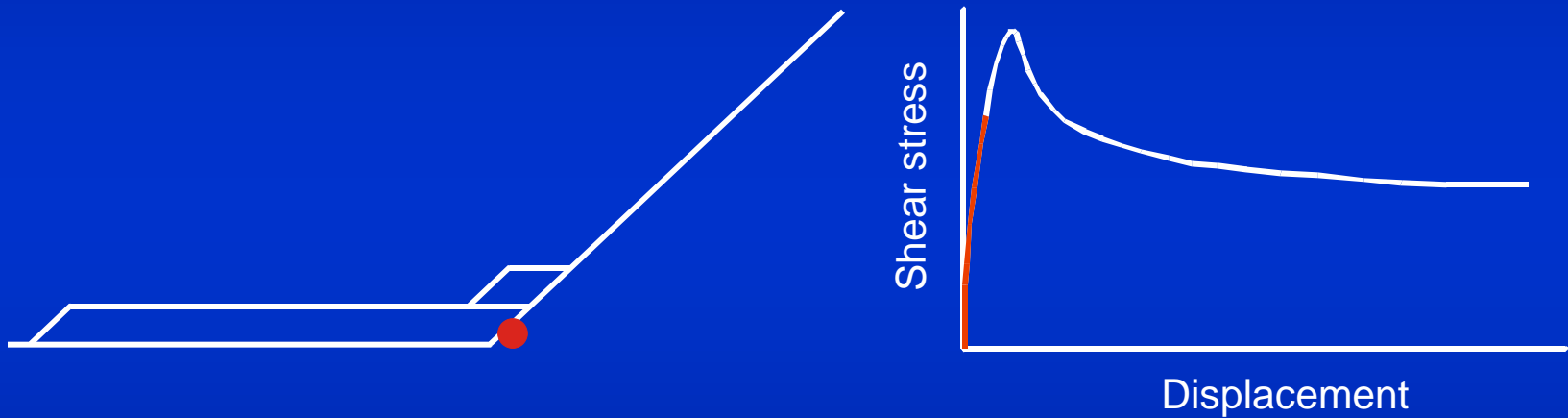



# Development of post peak shear strength: Veneer slope

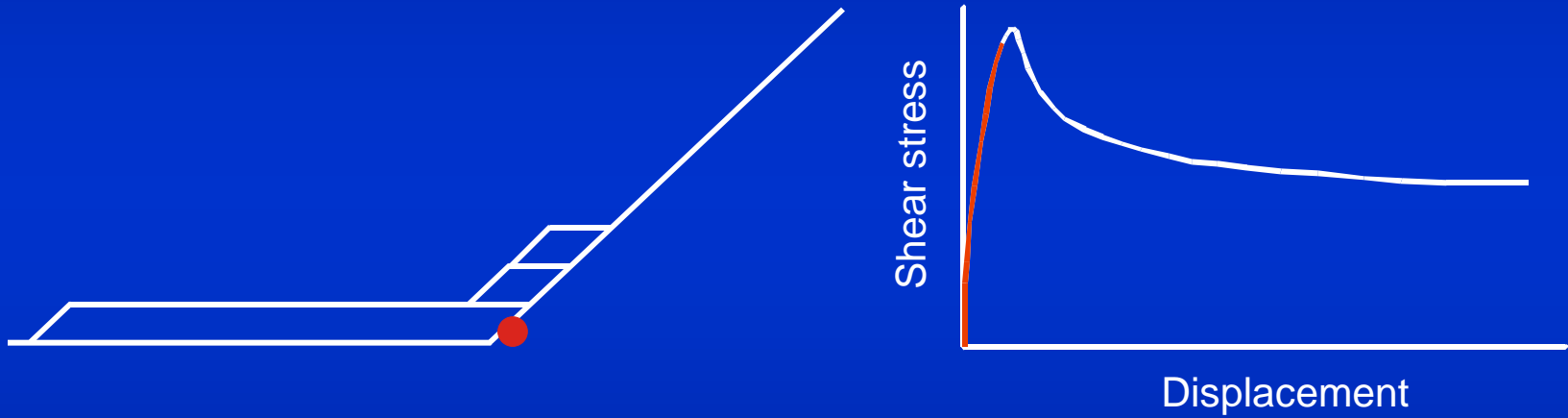

# Development of post peak shear strength: Veneer slope

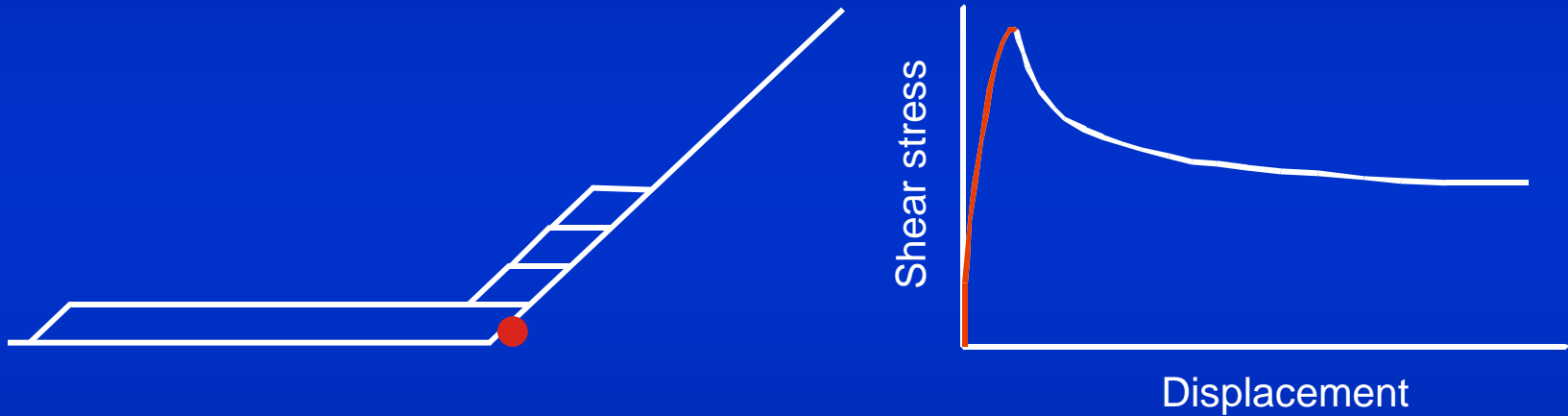

# Development of post peak shear strength: Veneer slope

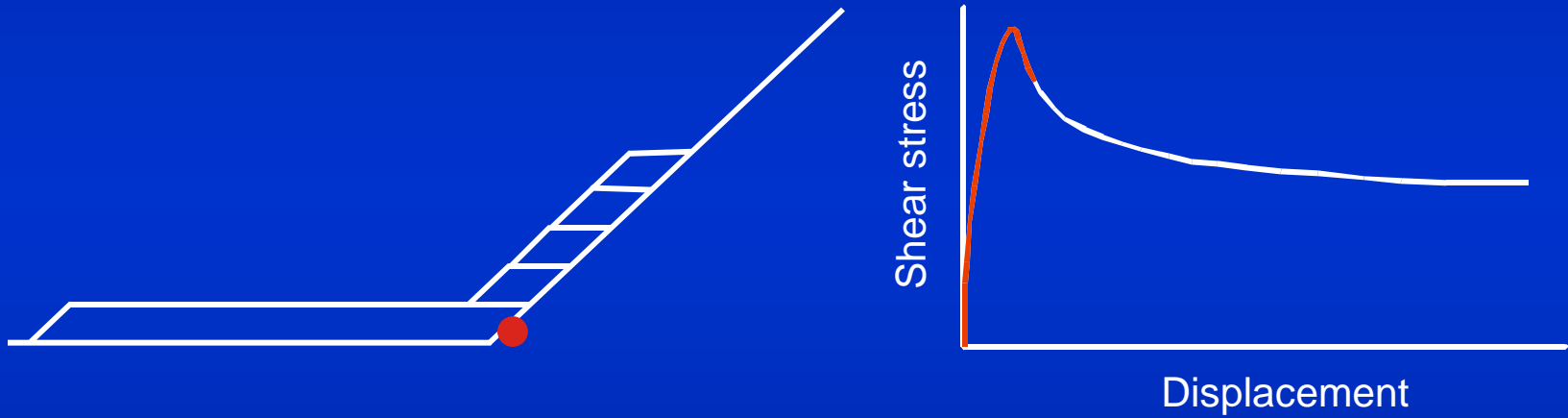

# Development of post peak shear strength: Veneer slope

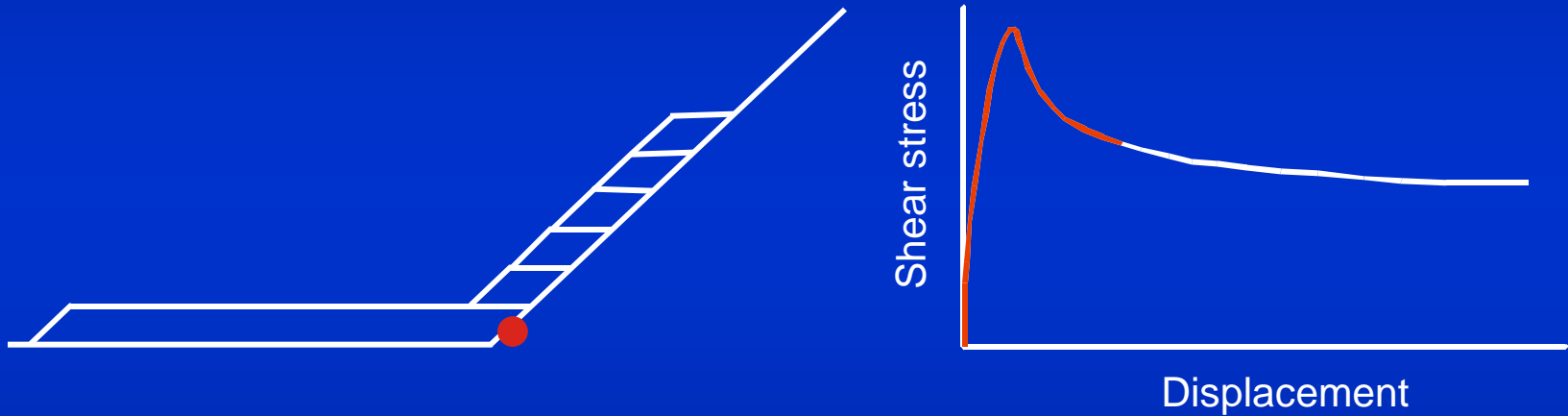

# Development of post peak shear strength: Veneer slope

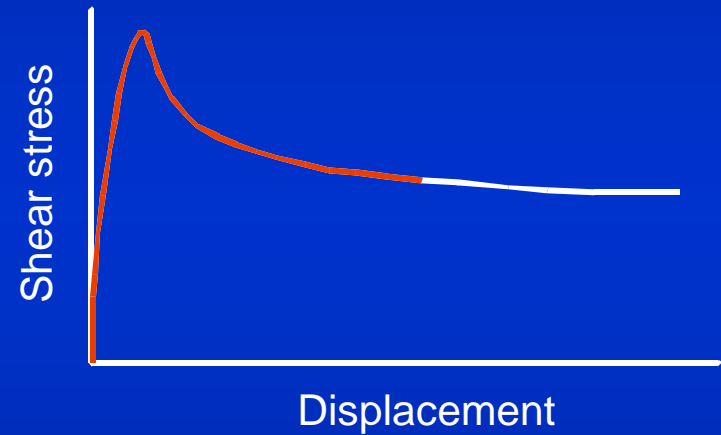
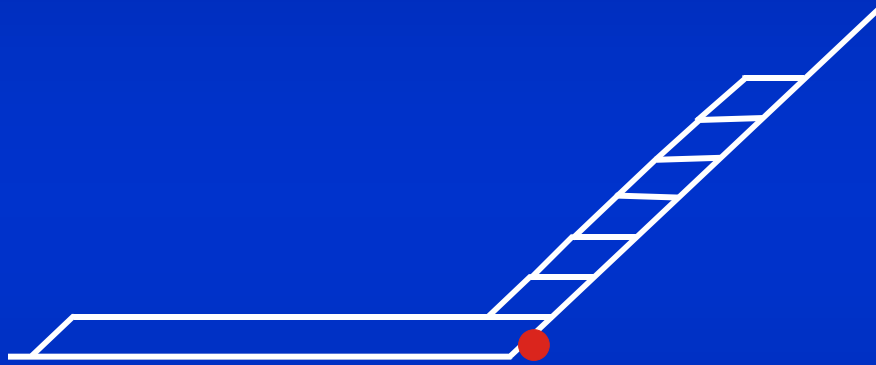

# Development of post peak shear strength: Veneer slope

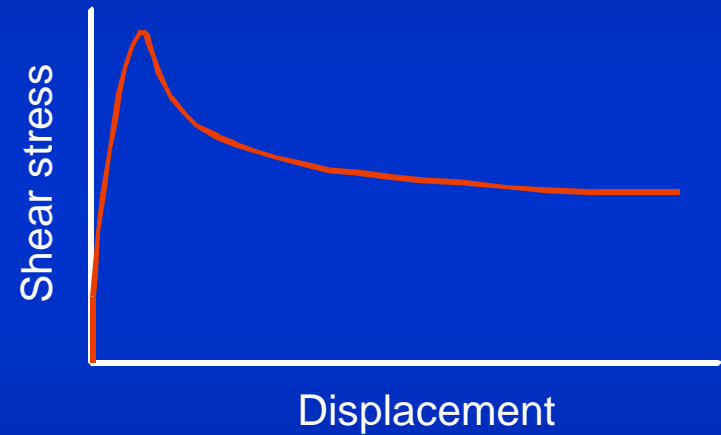
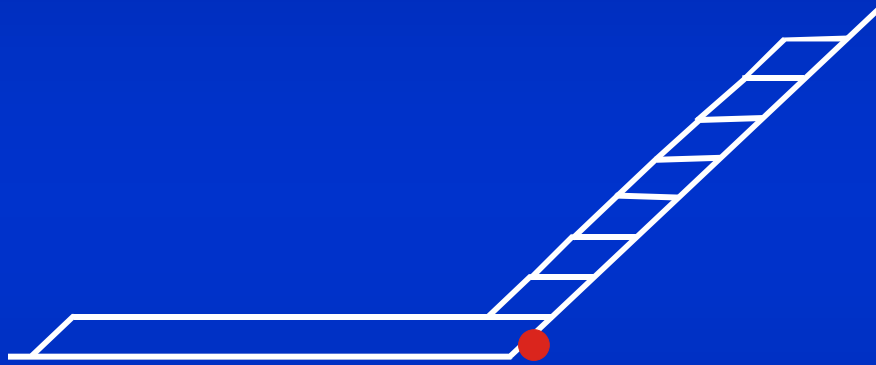

# Waste settlement generated post peak interface strengths (Jones 1999)

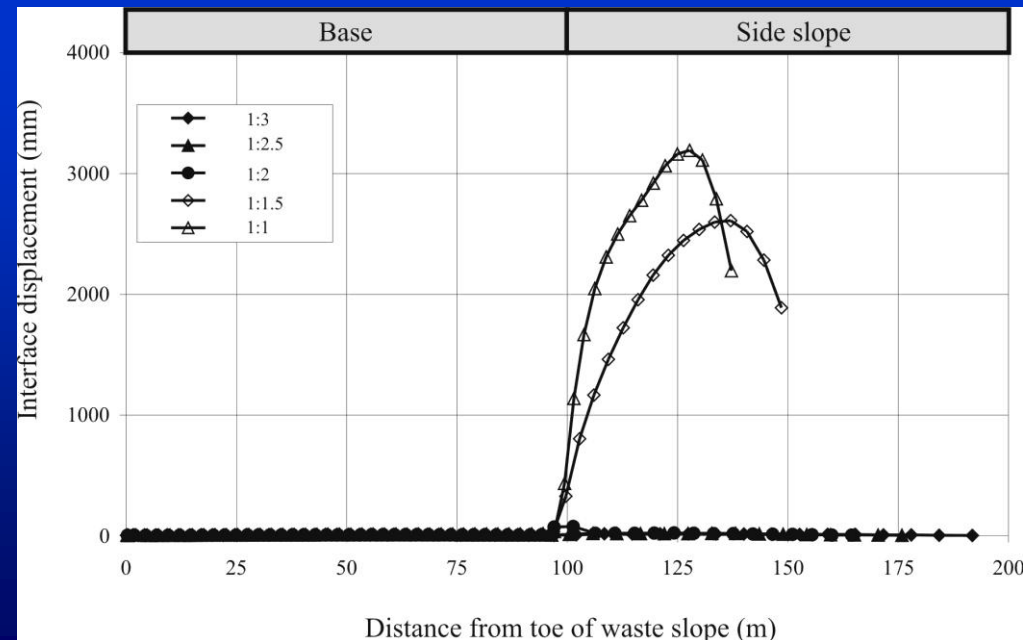
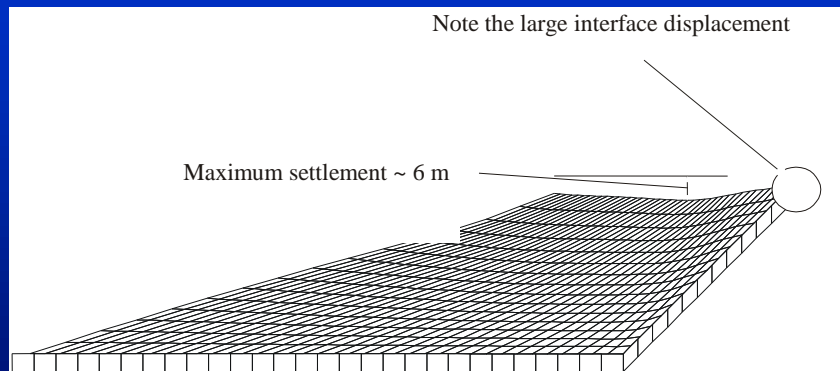
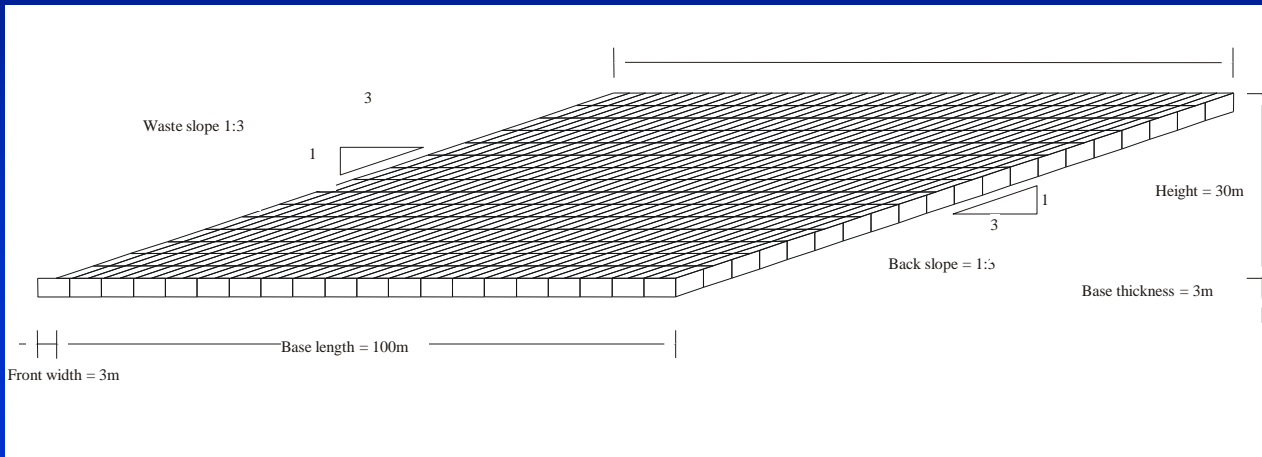

Variability of measured behaviour



# Uncertainty of test results!

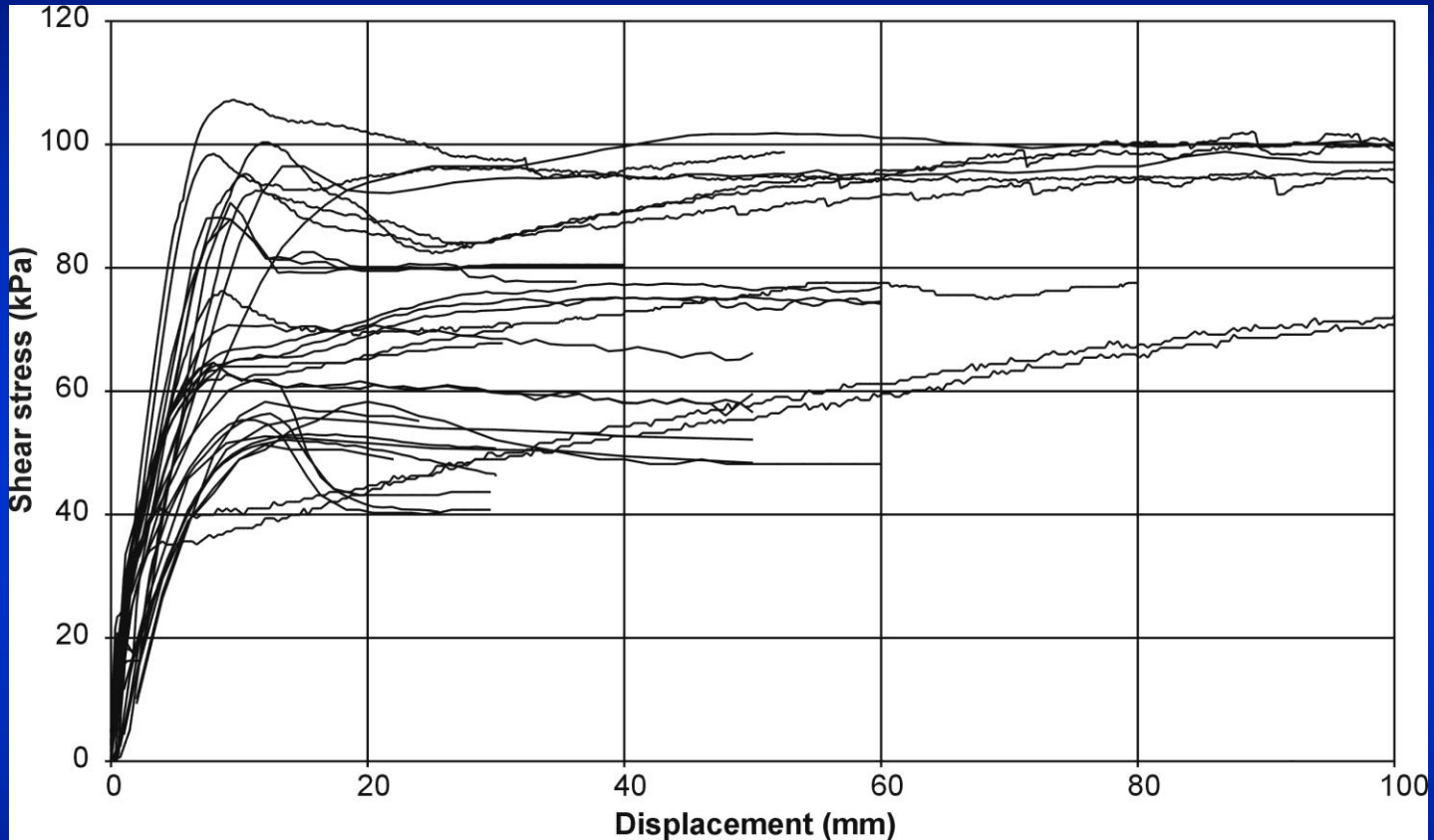

Results from German inter laboratory comparison tests on non-woven geotextile vs. sand interface (Blumel and Stoewahse 1998)

# German direct shear Inter-comparison tests

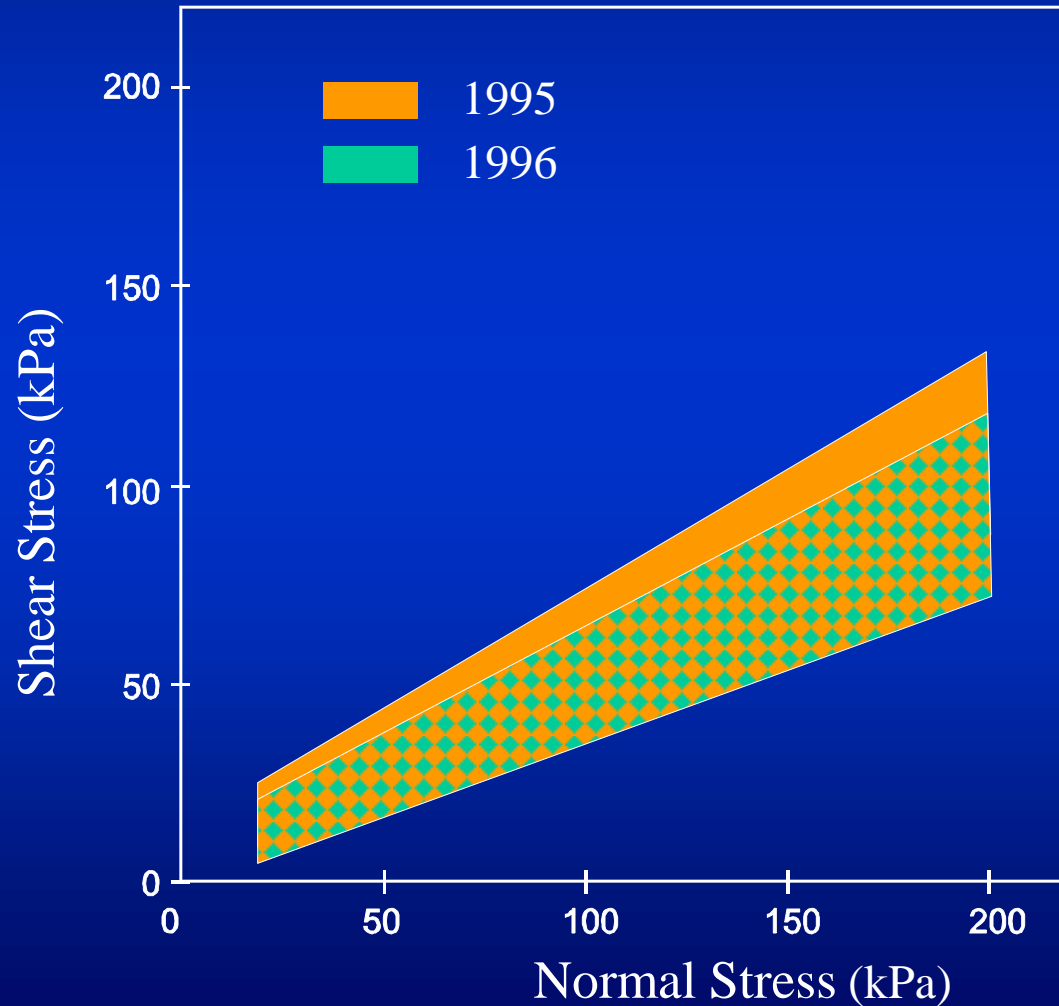

# European inter-comparison shear tests: Sand vs. non-woven geotextile

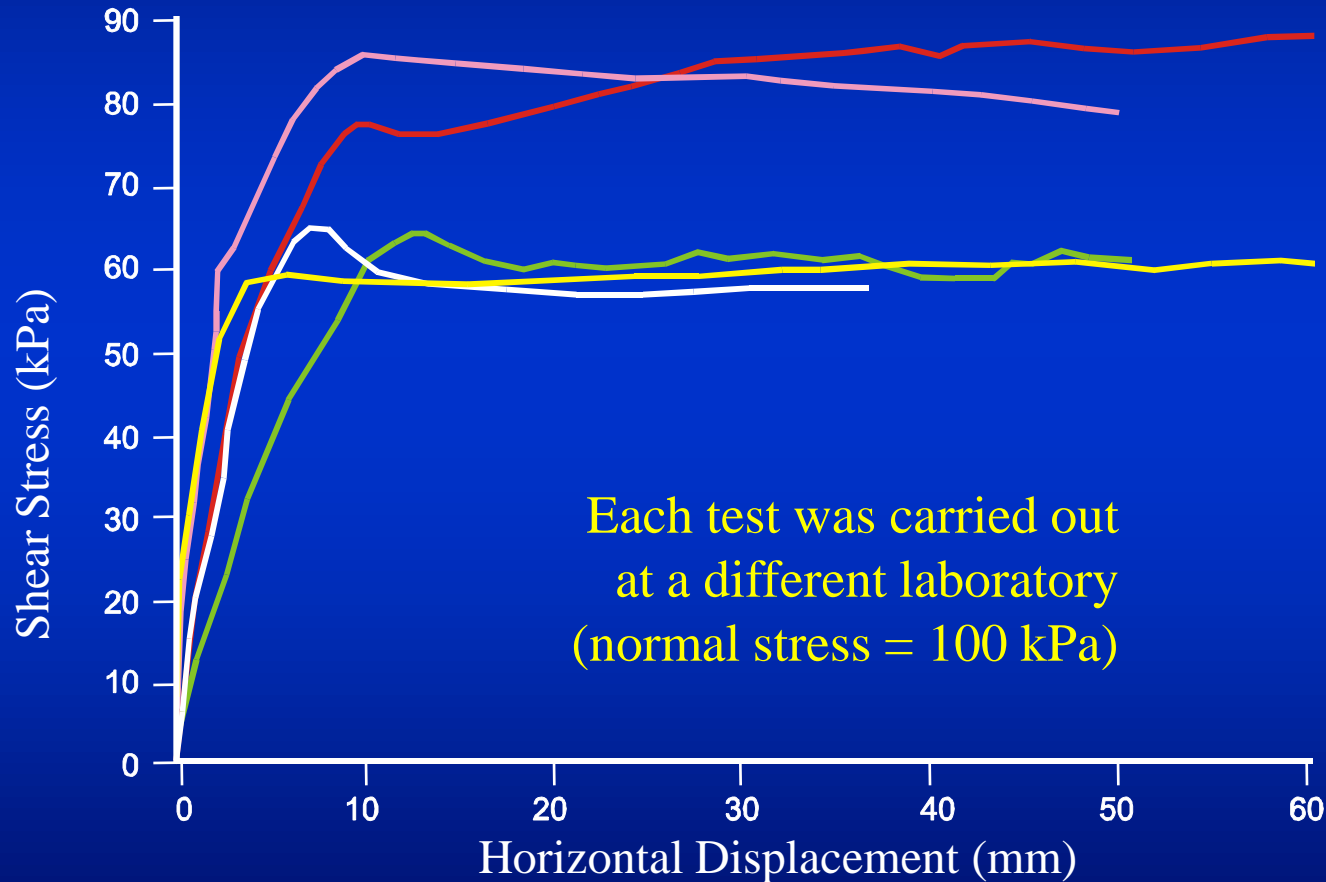

(Gourc 1997)

# European inter-comparison shear tests: Sand vs. geotextile peak strength

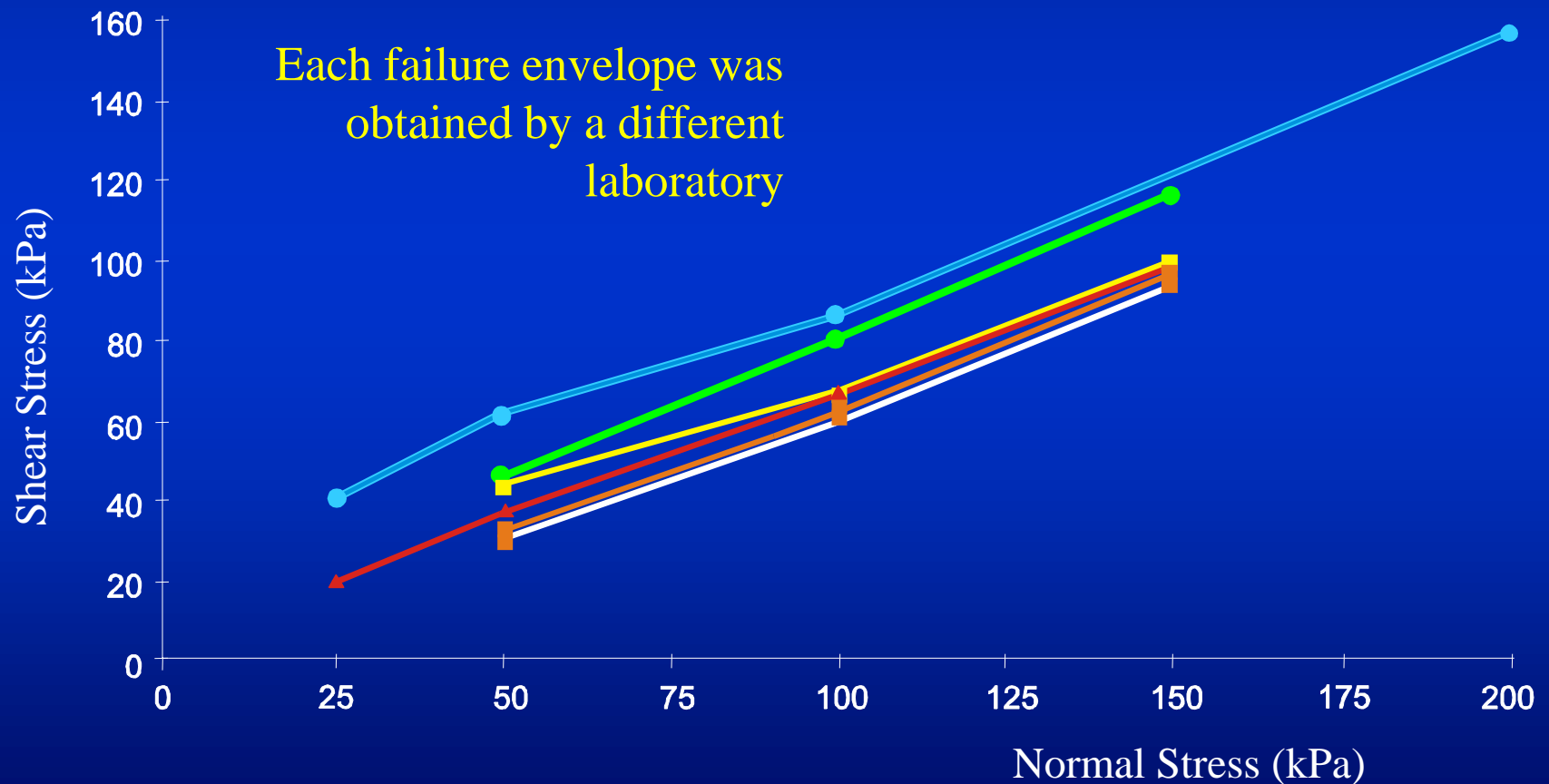

(Gourc 1997)

# Comparison of Different Shear Device Designs: Geomembrane vs. Geotextile Peak Strength (Blumel *et al.* 2000)

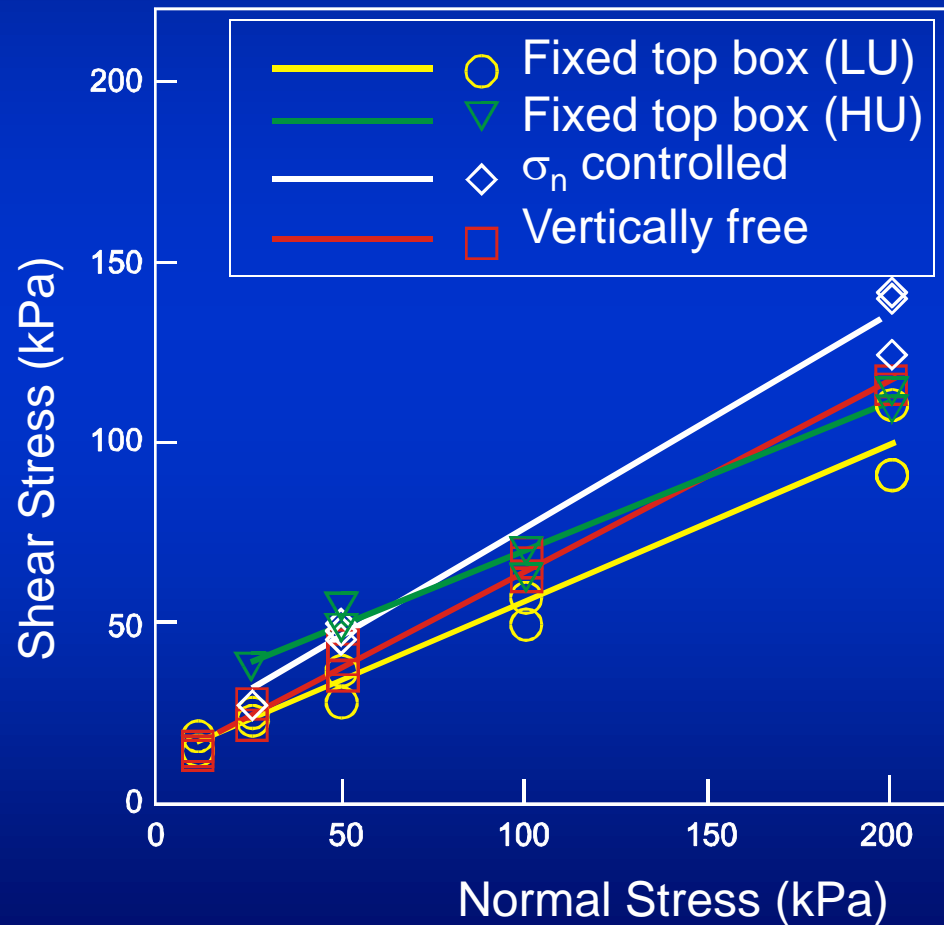

# Repeatability shear tests for one DSA and operator: Geotextile vs. sand

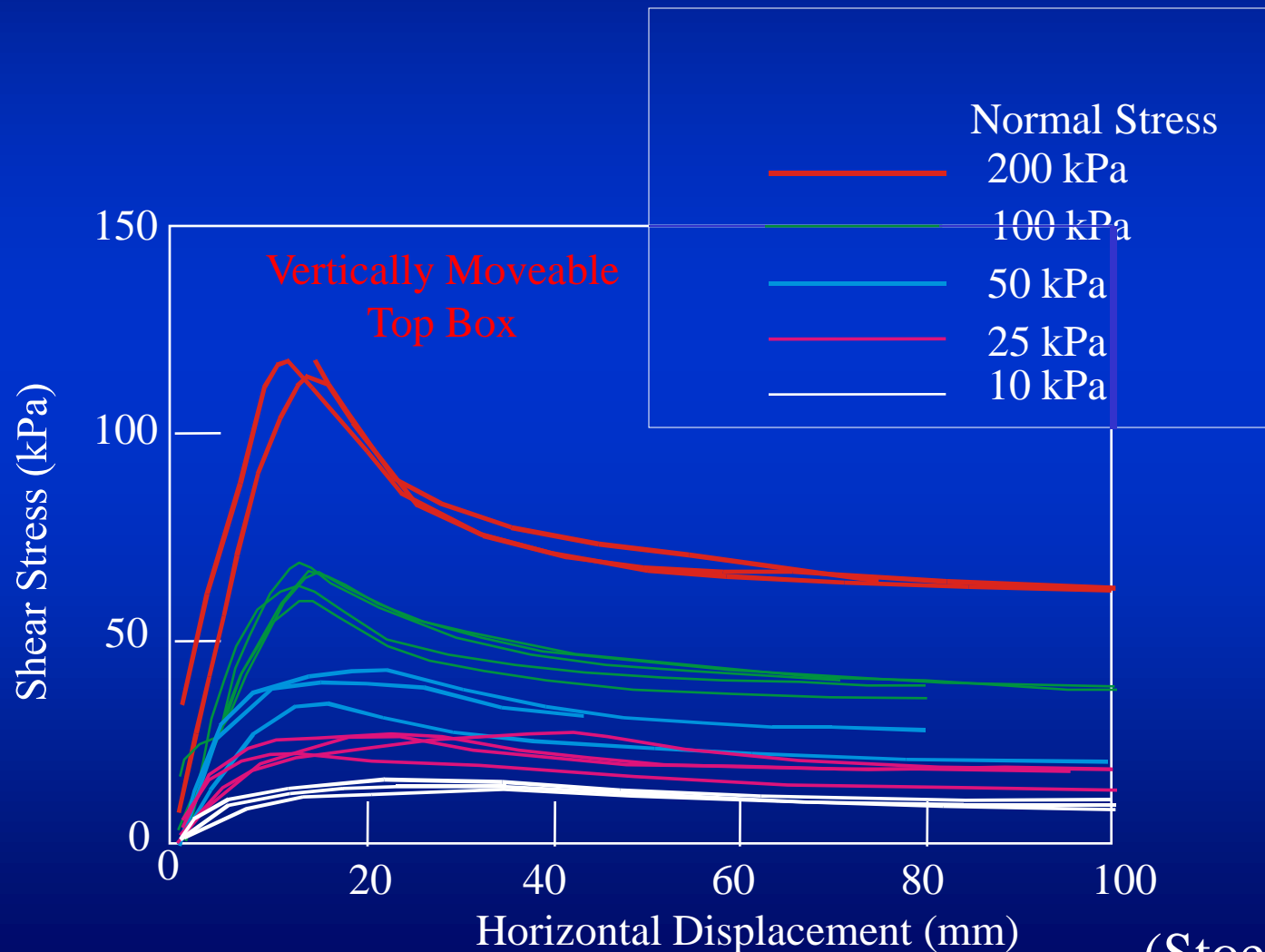

(Stoewahse 2001)

# Variability from repeatability tests

- inter-laboratory comparison test 1995
- inter-laboratory comparison test 1996
- △ Hanover University, repeatability tests
- ▽ Loughborough University, repeatability tests

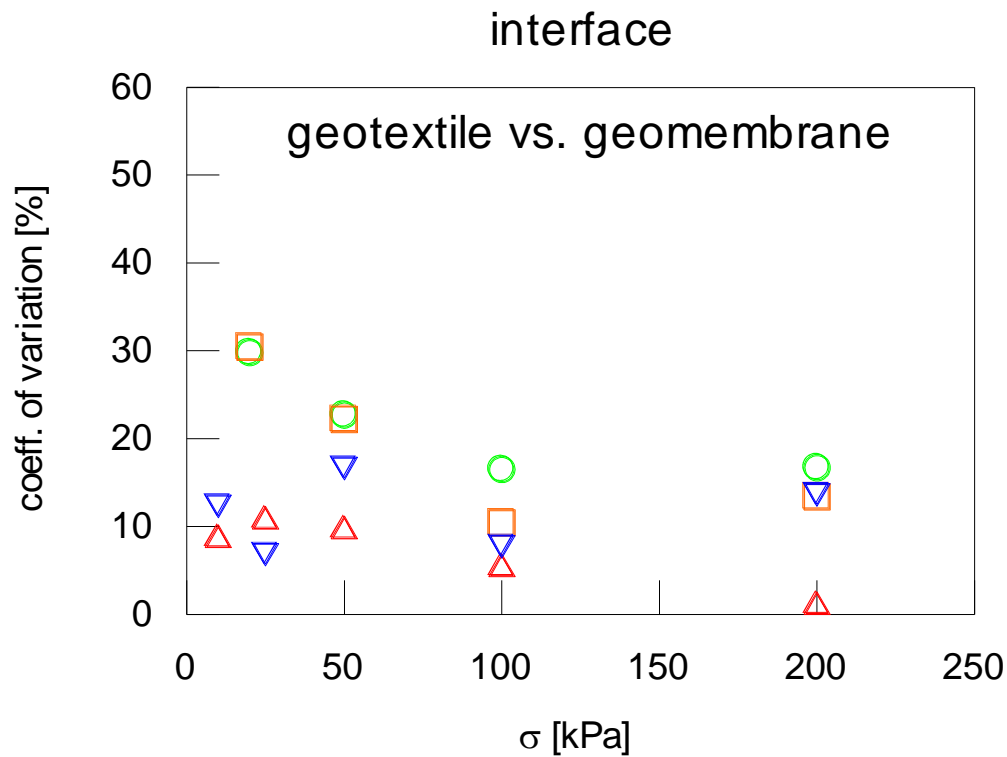

# Smooth geomembrane vs. geotextile: Repeatability tests

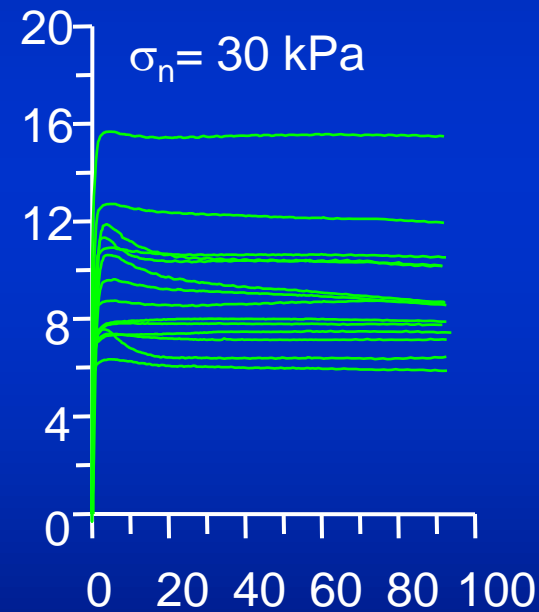
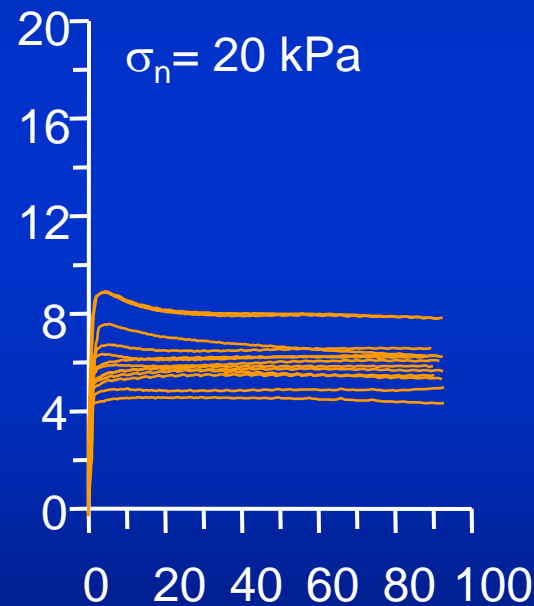
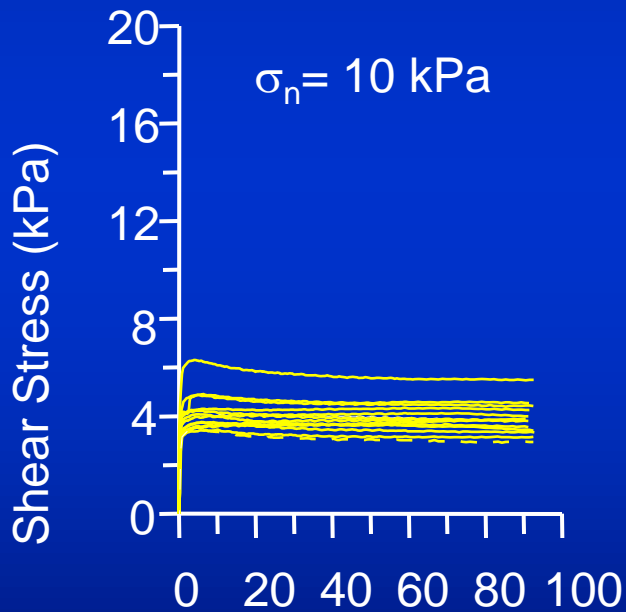

Displacement (mm)



# Smooth geomembrane vs. geotextile: Repeatability tests

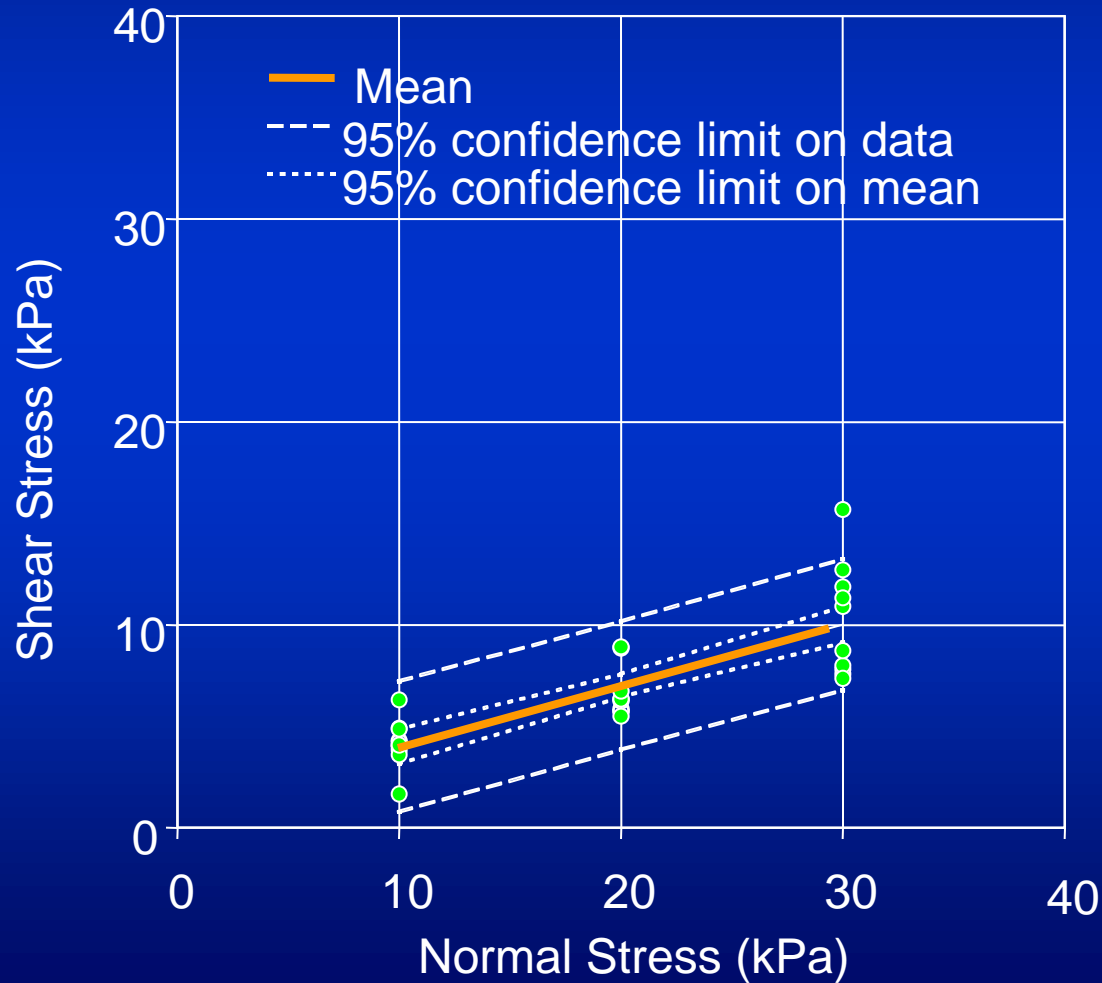

# Smooth geomembrane vs. geotextile: Repeatability tests

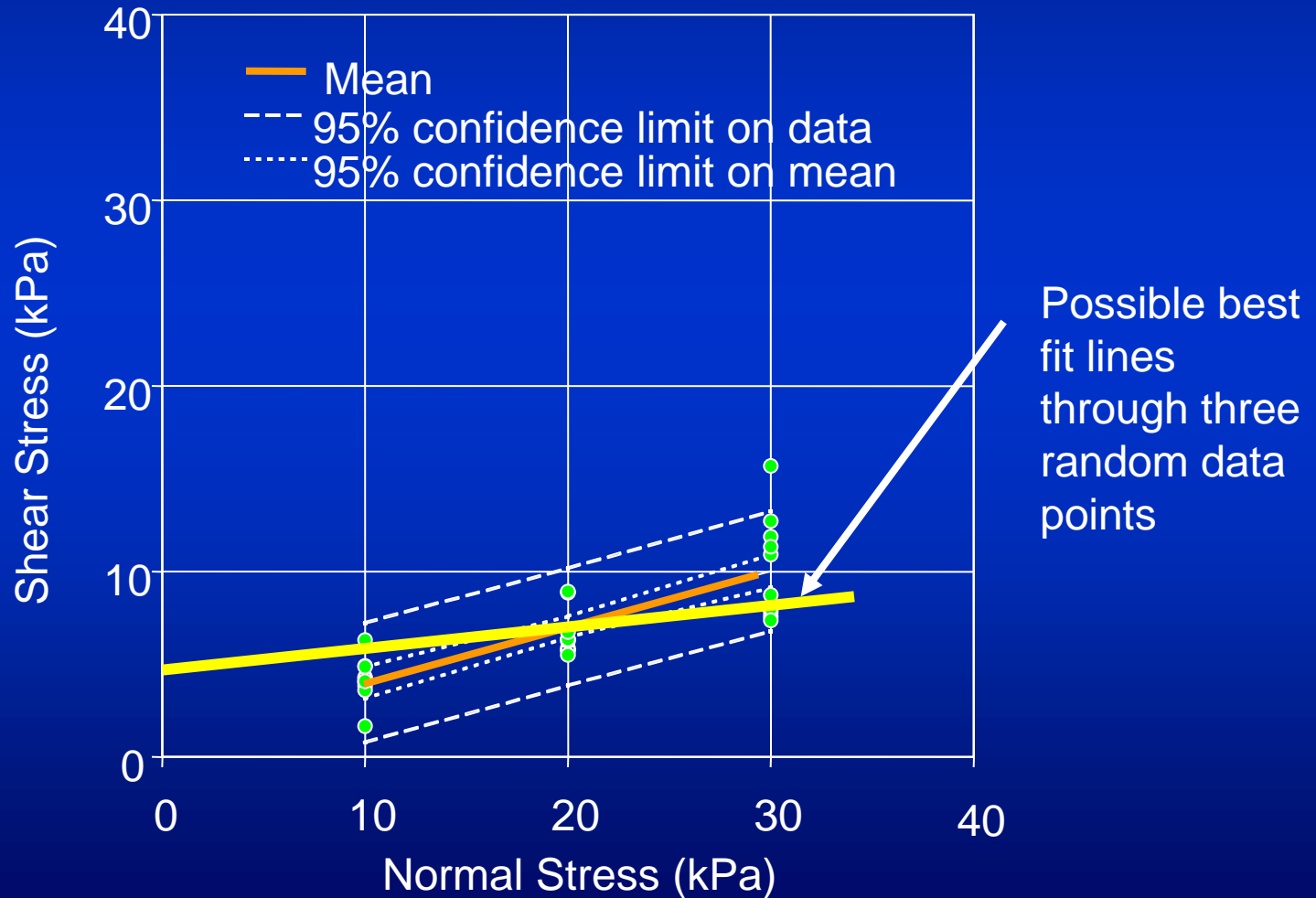

# Smooth geomembrane vs. geotextile: Repeatability tests

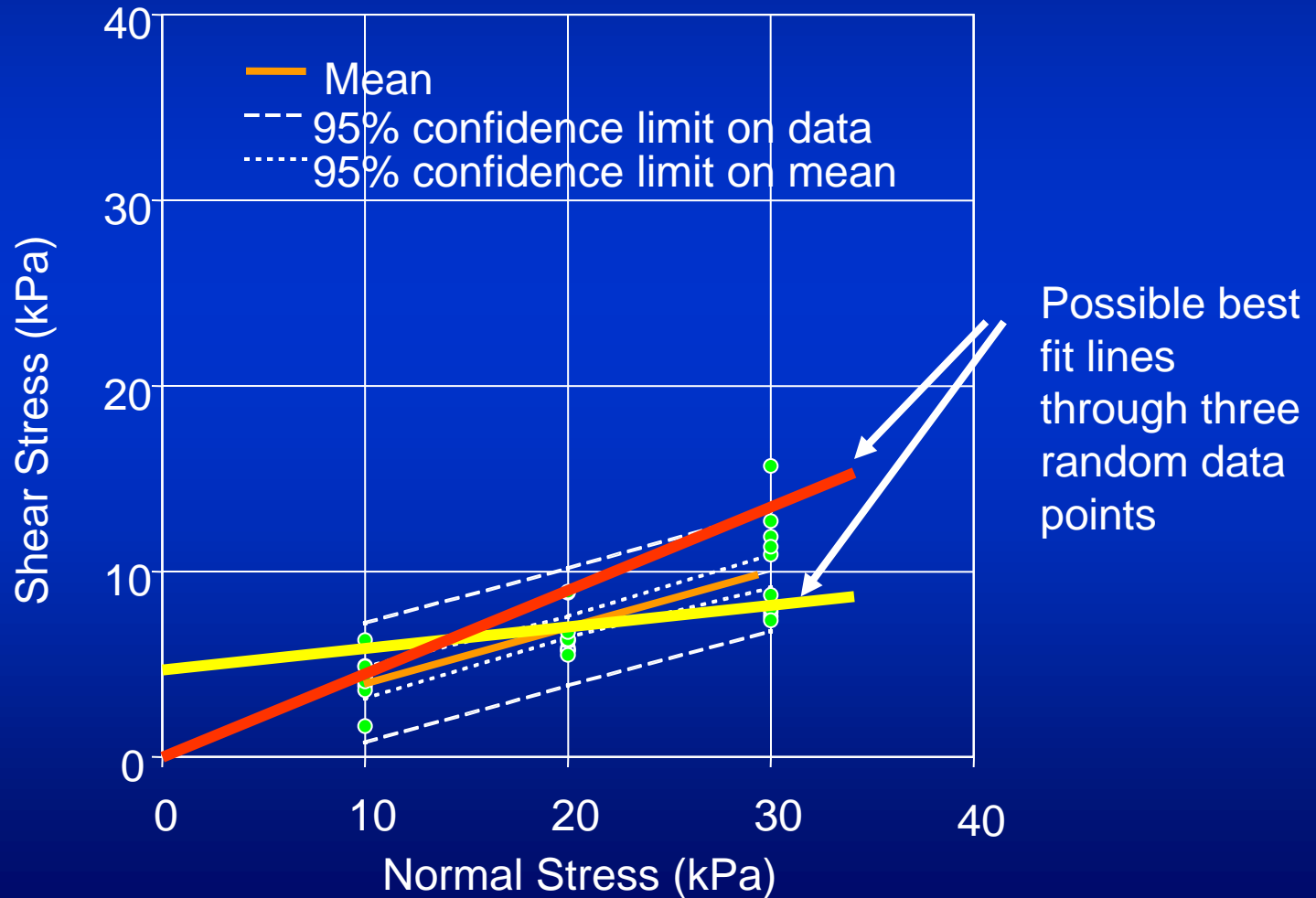

# Variability of gravel/non-woven geotextile interface: Data base and repeatability values

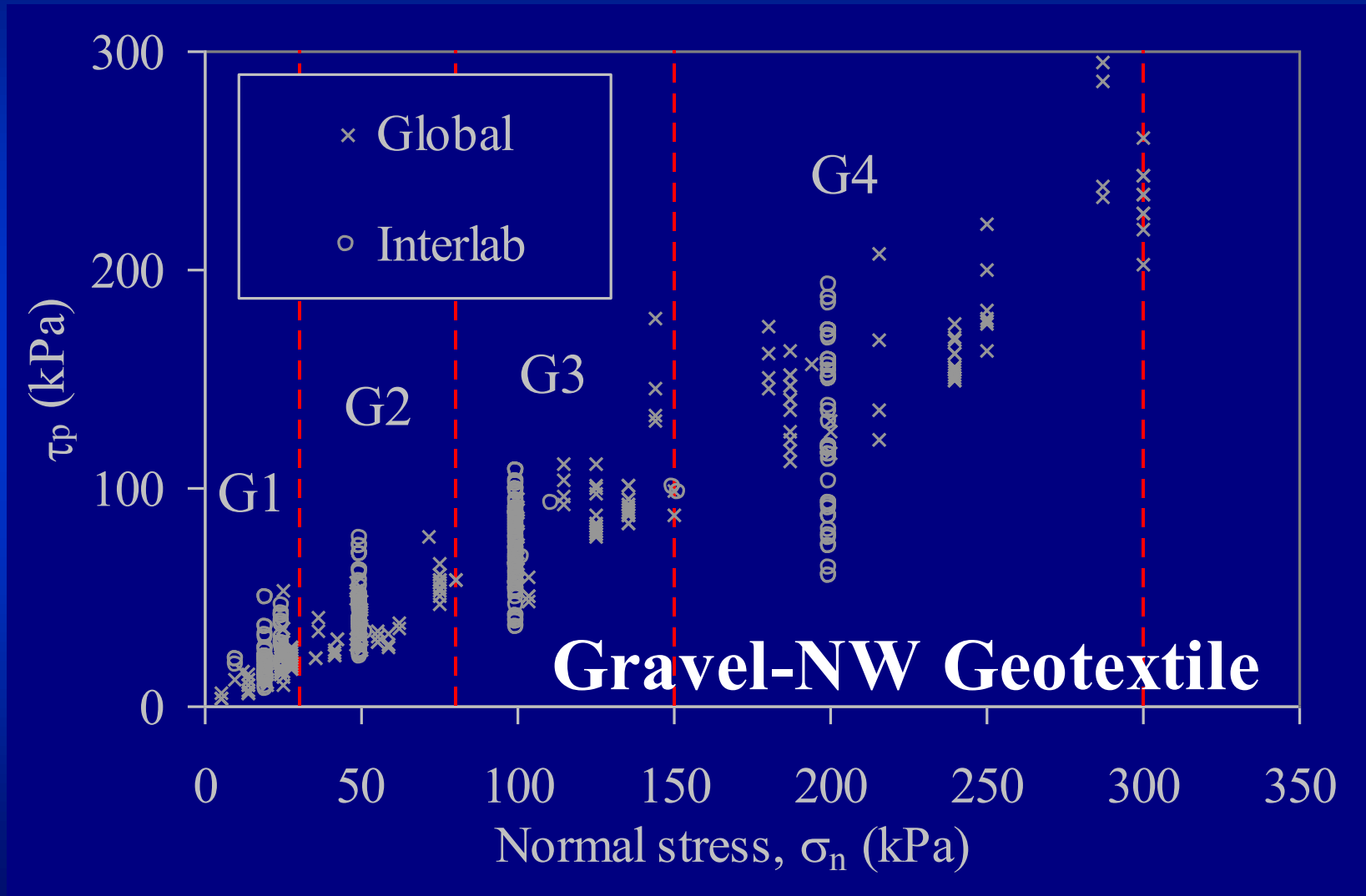

# Variability of gravel/non-woven geotextile interface: Data base and repeatability values

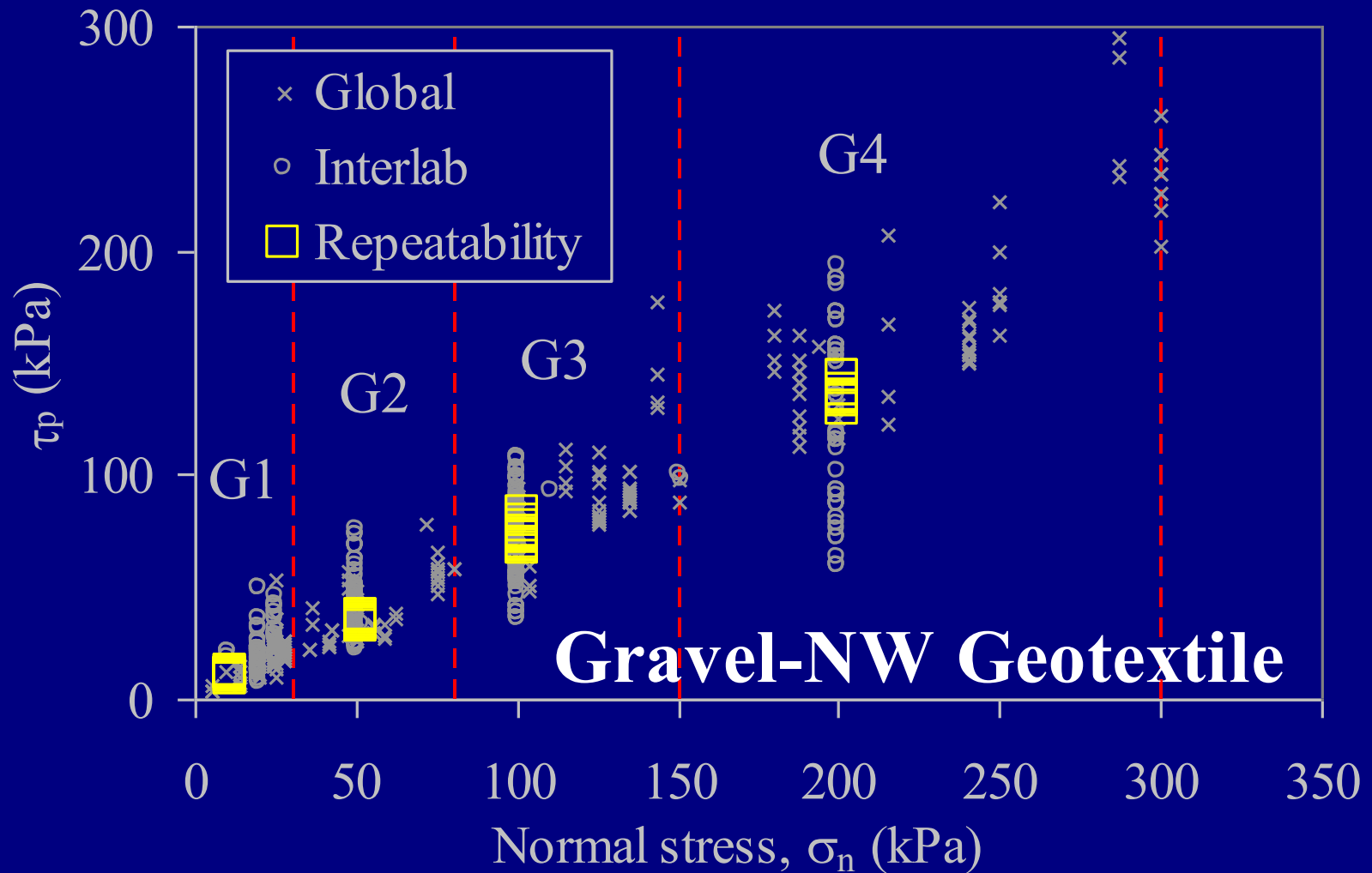

# Significance of variability

- Mean value of shear strengths from data base and repeatability may be similar, giving similar factors of safety, BUT uncertainty and hence probability of failure is completely different
- Final design must always be based on strengths from performance tests (i.e. using site specific materials and boundary conditions)
- Only use data bases of interface shear strength to inform assessment of measured values

Obtaining interface shear  
strength parameters for use in  
design

# Characteristic values for use in design

*“A cautious estimate of the value affecting the occurrence of the limit state.”*

*Eurocode 7 (1997)*



# Analysis to obtain characteristic strength parameters

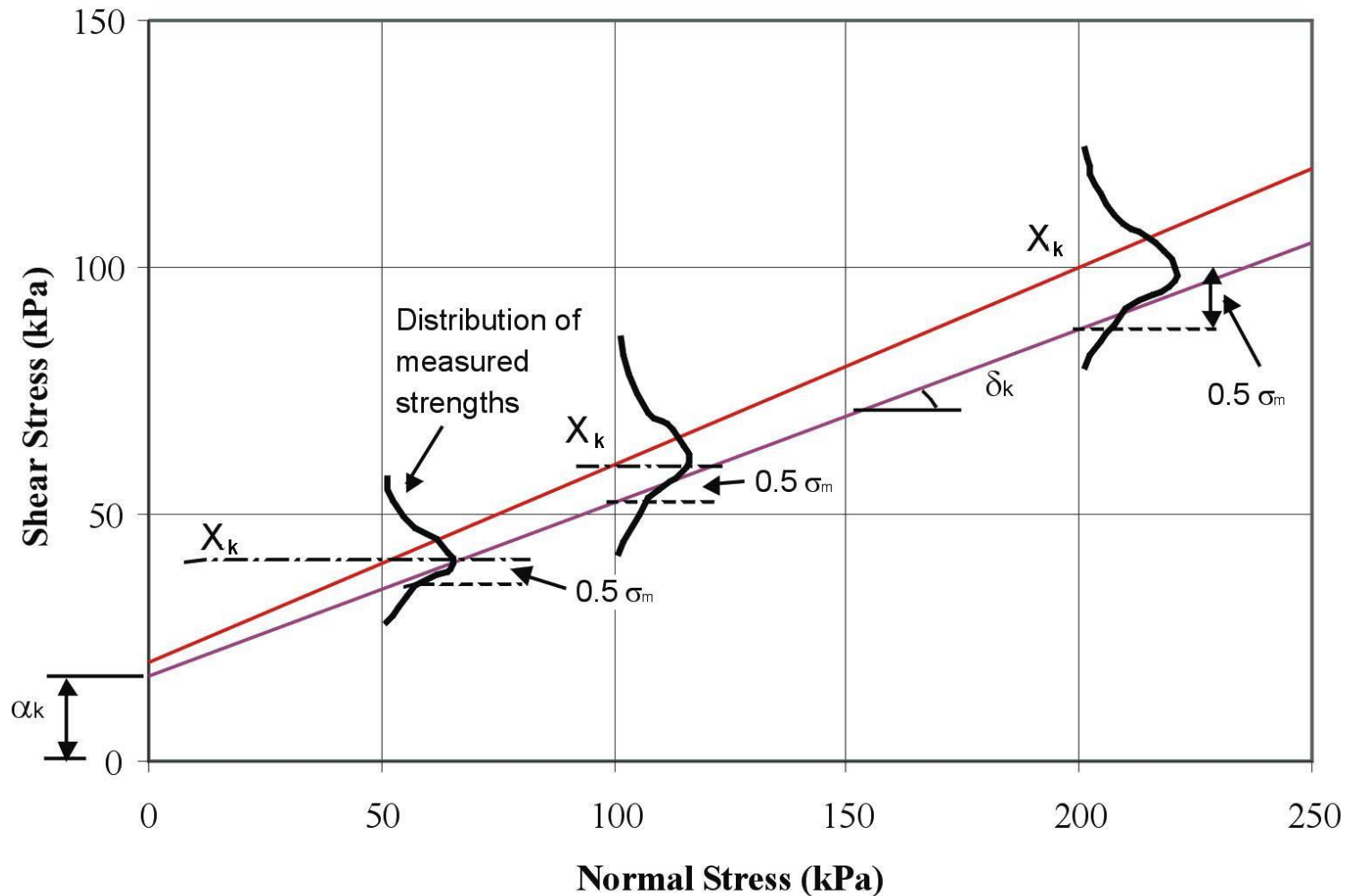

# Statistical approach

$$X_k = X_m - 0.5 \sigma_m$$

Where:

$X_k$  is characteristic value

$X_m$  is mean value of test results

$\sigma_m$  is standard deviation of test results

# How many tests should be conducted?

*One test at each normal stress is not enough!*

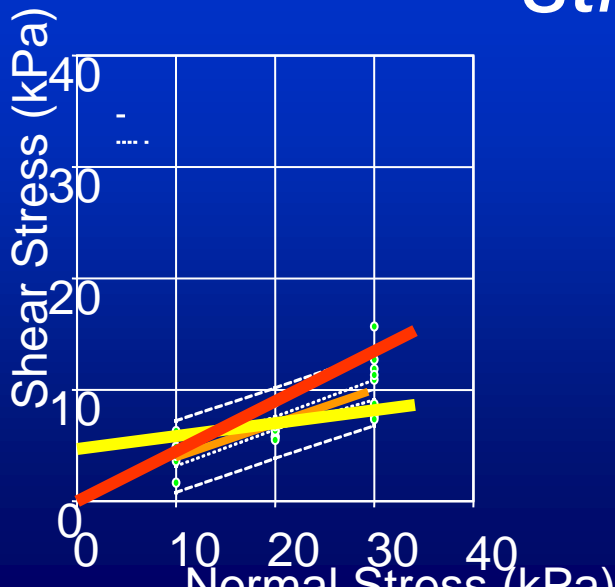

# Selection of characteristic values

- Generation of site specific statistical data
- Lower bound of limited repeatability data
- Method based on statistical data from published studies

# Generation of site specific statistical values

Carry out a minimum of 4 No. tests at each  
normal stress

# Are the measured strengths mean values?

Make an assessment based on experience of  
Engineer and personal judgement backed by  
published data

If in doubt, use conservative lower bound  
values or do more tests.

What are the implications of variability in measured values on design?

# Probability of failure: LE analysis

- First order, second moment reliability based method - i.e. using mean and standard deviation of parameters (Duncan 2000)
- Two cases considered:
  - Veneer
  - Waste slope



# What is an acceptable $P_{ft}$ ?

• Target probability of failure, $P_{ft}$	
• Qualitative	• Quantitative
• Performance level (USACE, 1997)	• Degree of damage (Cole, 1980)
• Risk (Gilbert, 2001)	• Actual failure rates (Baecher, 1987)
• <b>LOW</b> (cover & veneer slope as infinite)	• Existing structures (Phoon <i>et al.</i> , 1995)
• <b>MODERATE</b> (temporary base liner slope, cover & veneer slope with buttress and reinforcement)	• Function (Koerner & Koerner, 2001)
• <b>HIGH</b> (permanent base liner slopes)	• Cost (Gilbert, 2001)

# What is an acceptable $P_{ft}$ ?

- Selection of  $P_{ft}$  for veneer cover design based on minor repairs (Cole, 1980), moderate risk (Gilbert, 2001) and below to above average performance level (USACE, 1997).

$P_{ft}$  estimated in the range of  $10^{-3}$  to  $10^{-2}$ , between mine slopes & foundations

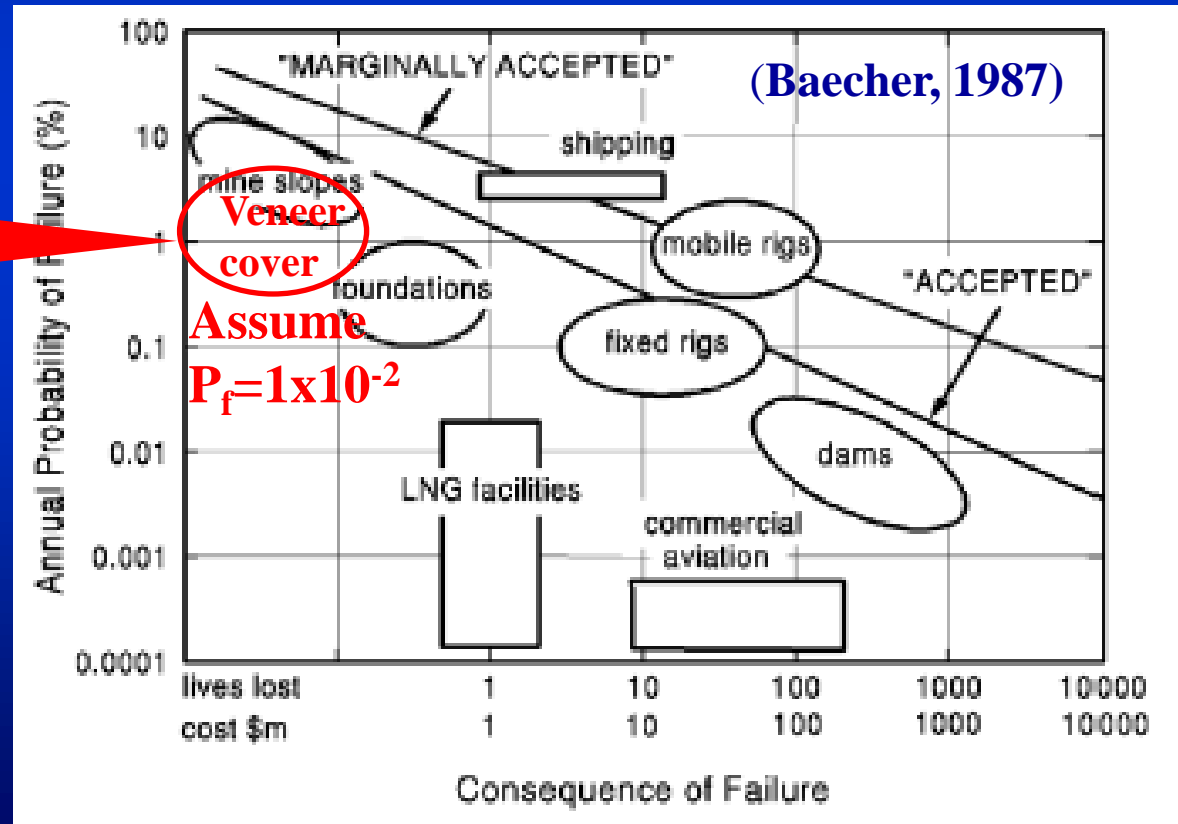

# Implication of $P_f$ approach: Veneer

- Interface shear strength from global database yield much higher  $P_f$  although the FS for both data sets are similar
- Two methods of reaching accept.  $P_{ft}=1 \times 10^{-2}$ :

1) Reduce the variation

( $V_{\text{strength}}$ ) via further tests

2) Increase FS,

(e.g. changing to higher interface shear strength material - increase of cost)

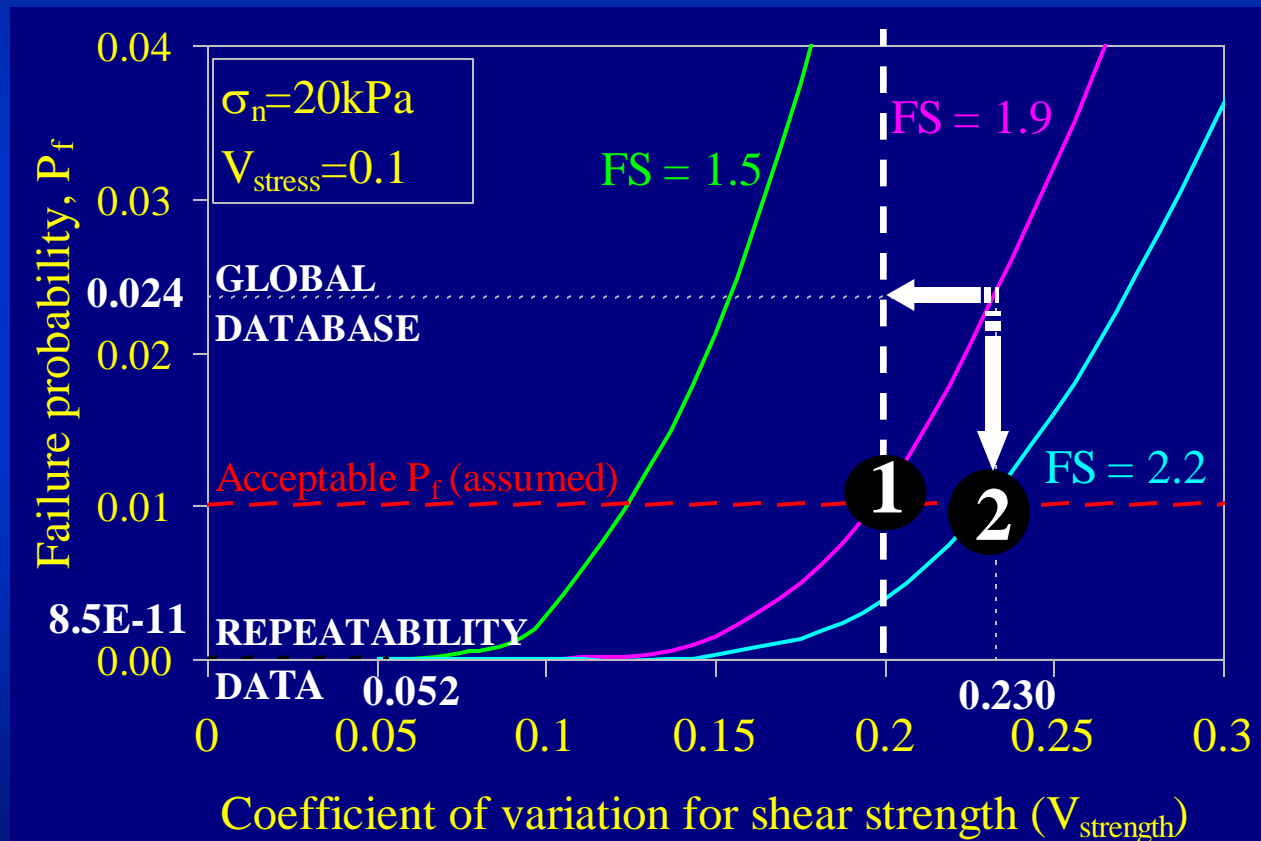

# Reliability-based design chart for target FS of 1.5 and $P_f$ of $1 \times 10^{-2}$

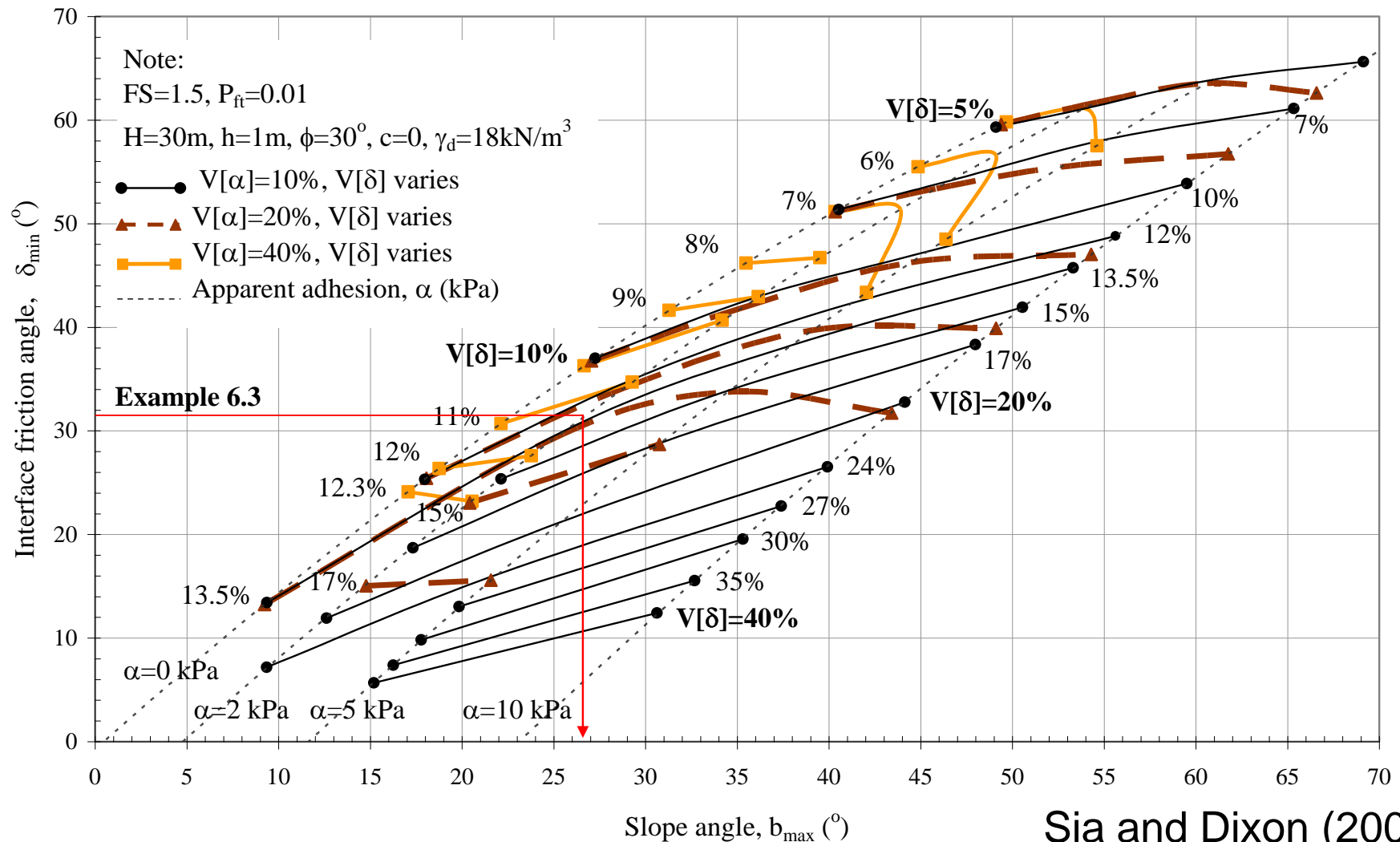

# Implication of $P_f$ approach: Waste slope

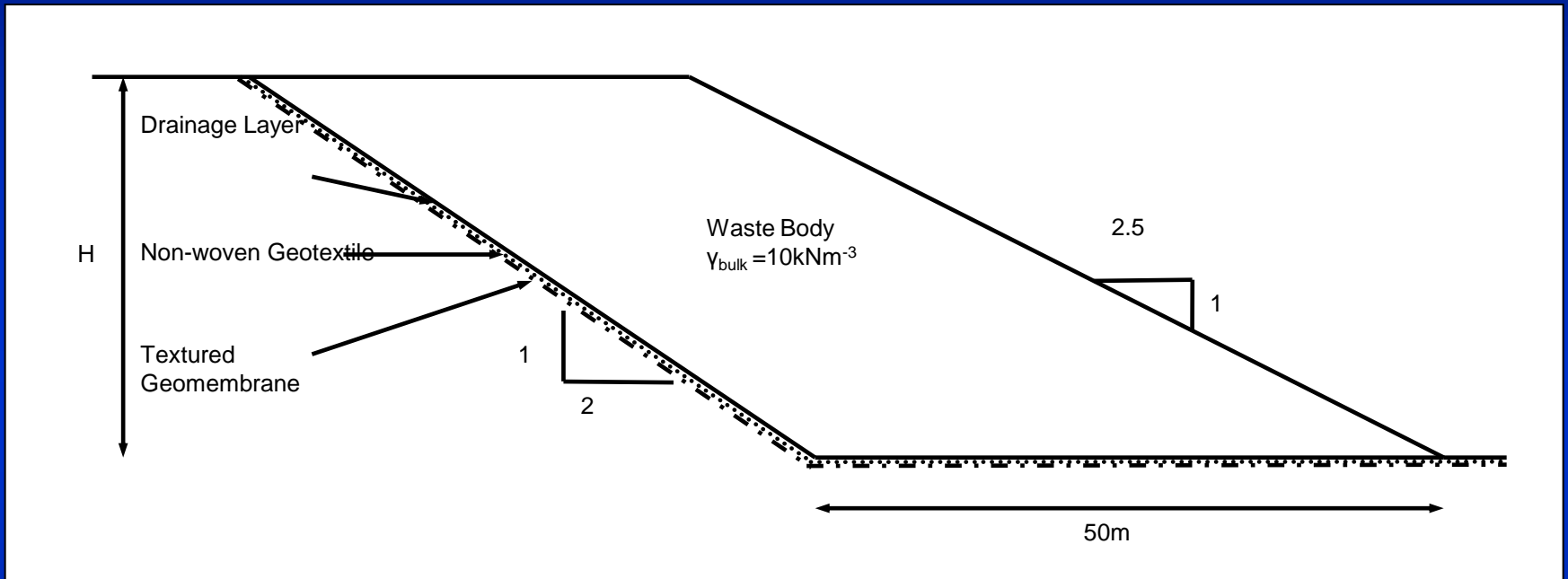

## Interfaces analysed

- Textured geomembrane vs. non-woven geotextile
- Non-woven geotextile vs. coarse soil

General database values used

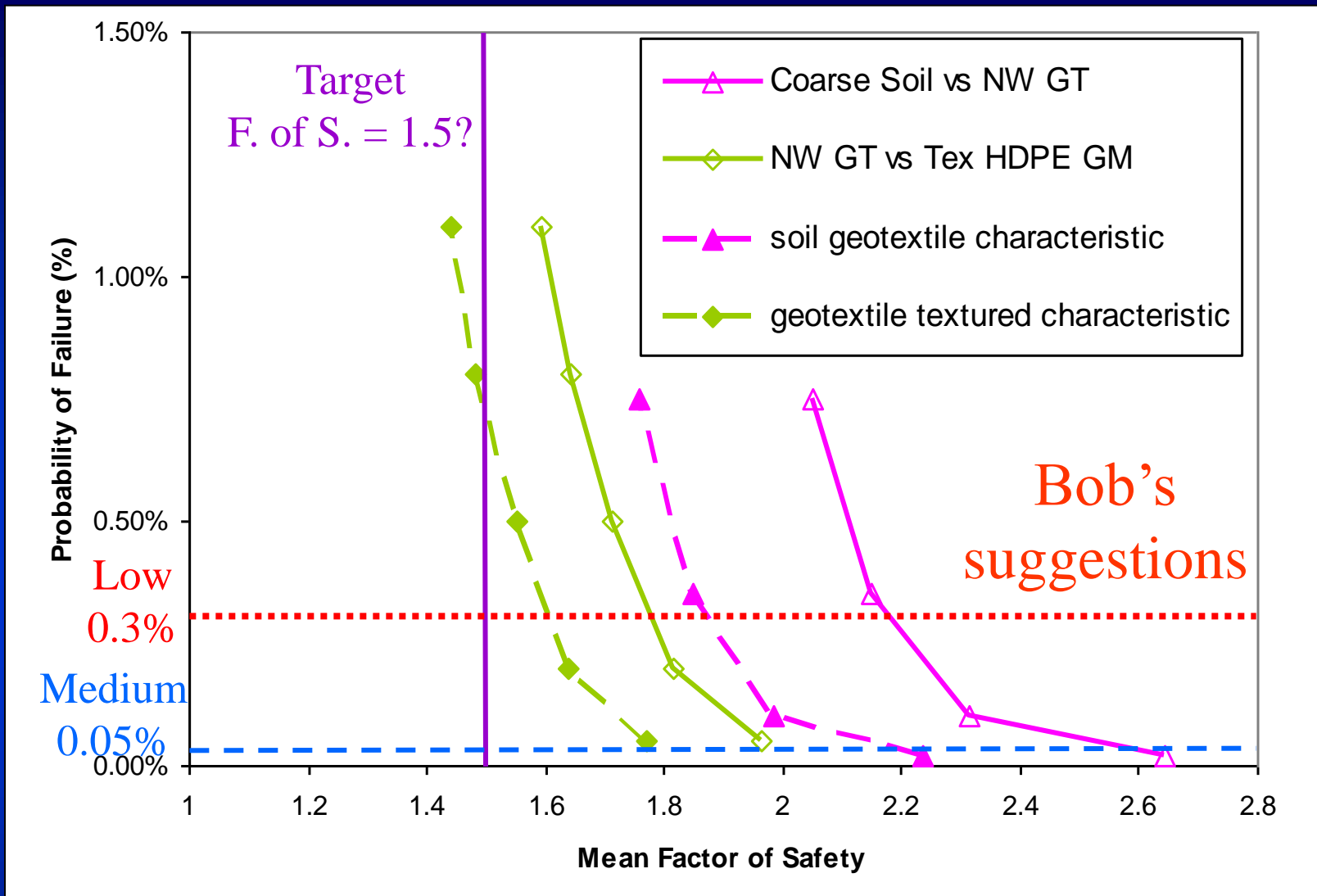

Probability of failure vs. factor of safety for waste body stability, showing the relationship between the mean and characteristic values for factor of safety, based on combined data.

# Reliability of landfill LE analysis

- Current design practice uses target Factor of Safety in LE analysis (e.g. 1.5) based on 'conservative' estimates of interface strengths
  - Engineering judgement - common
  - Statistical derivation – rare
- Benefits of obtaining statistical data:
  - Quantitative analysis of design reliability
  - Justification of costs for site specific testing

# Probability vs. consequences of failure

Probability	0.3%	0.05%	0.01%
Consequences	Low	Medium	High
Examples	Veneer side slope	Capping	Waste body

(After Koerner & Koerner 2001)

- Waste slippage in this study  $P_f \gg 0.01\%$  even with Factor of Safety = 1.8
- Discussion required between regulators, owners and designers to define acceptable values of  $P_f$



# Probabilistic analysis of waste settlement induced stresses in liner (Sia and Dixon)

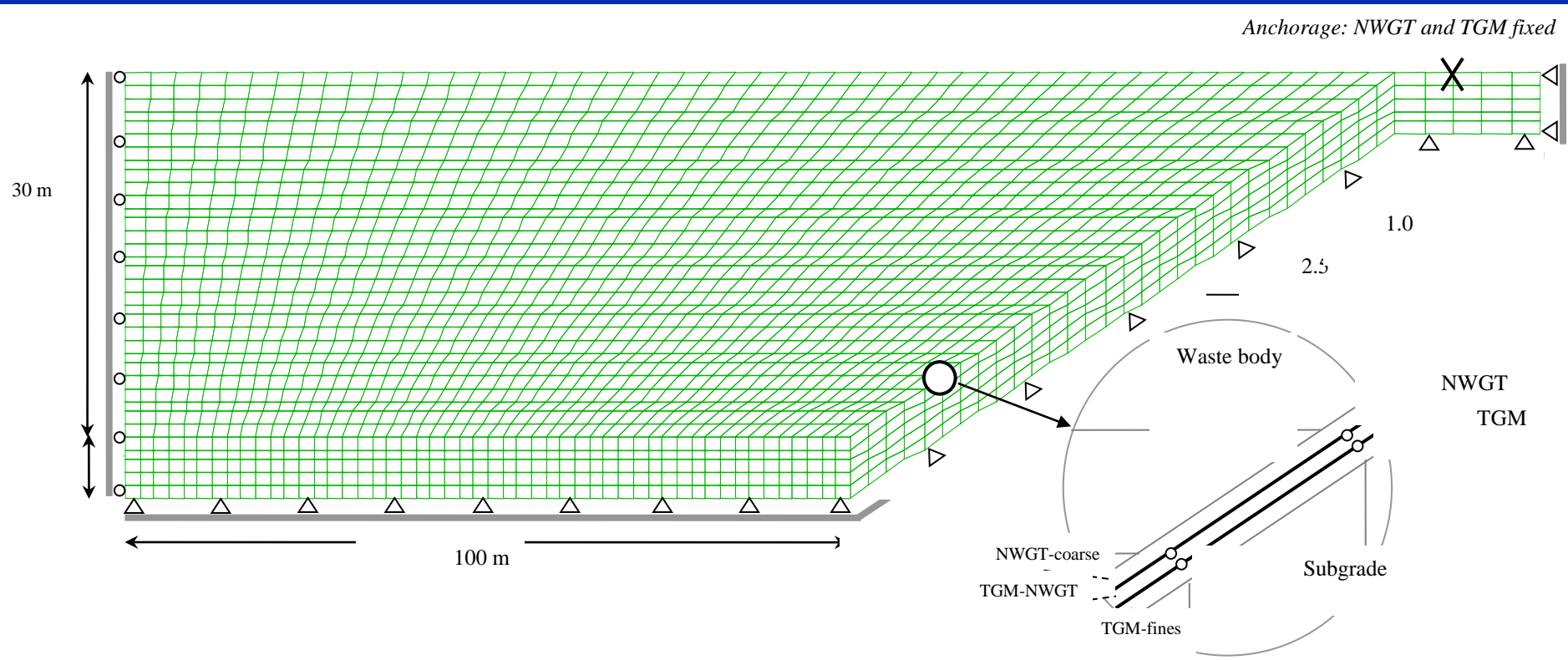

# Factors included in analyses

- Statistical variability of:
  - Interface shear behaviour (strength and stiffness)
  - Waste engineering properties (unit weight and stiffness)
  - Geosynthetic tensile elastic moduli
- Waste placed in 6 lifts, 5 metres each
- Ranges of slope angle and waste stiffness
- Short term construction condition only (i.e. no waste degradation)

# Multiple FLAC analyses

- Probability distributions and ranges are assigned to input parameters (i.e. normal, uniform etc) to assess all possible measured values
- Monte Carlo simulations involve random sampling of parameters from the probability distributions to assess possible combinations of values
- Minimum of 250 FLAC analyses of staged construction for each design case

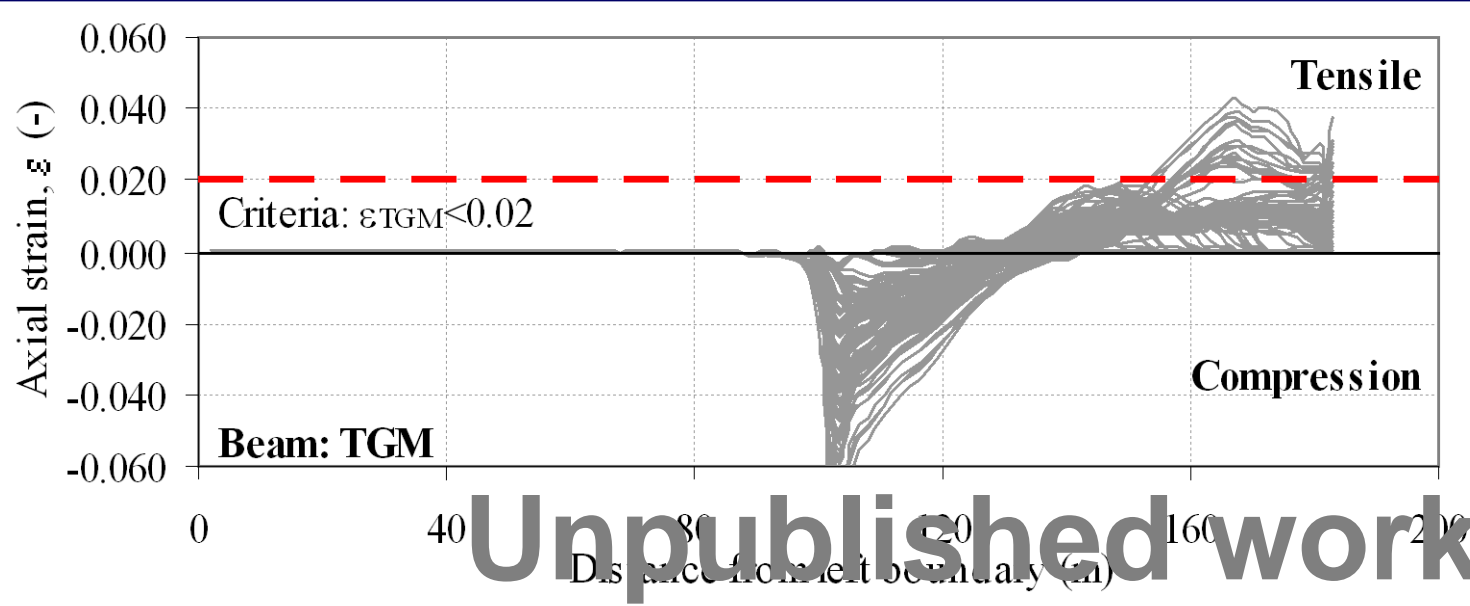

Strain in liner

Unpublished work of Sia and Dixon

Movement of liner!

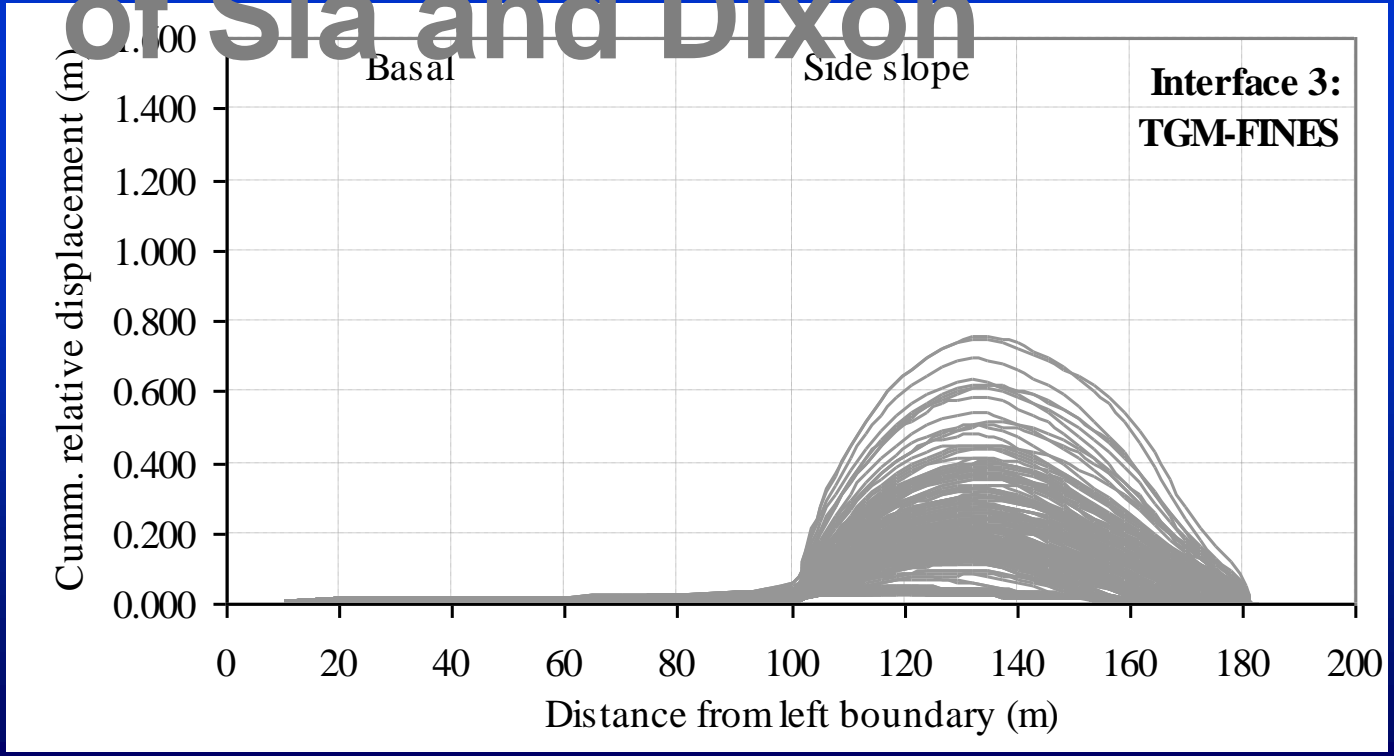

# Objective of current research (Zamara, LU/Golder Associates)

Conduct site experiment to monitor a side slope lining system during and post waste placement with a range of instrumentation in order to **validate current industry numerical models** (Zamara et al. 2010)



Milegate Extension Landfill



Sequence of lining slope



Pressure cells



Geomembrane placement

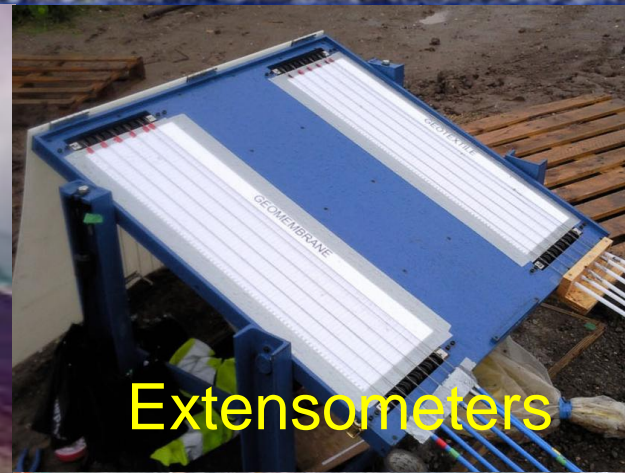

Extensometers



Demec gauges

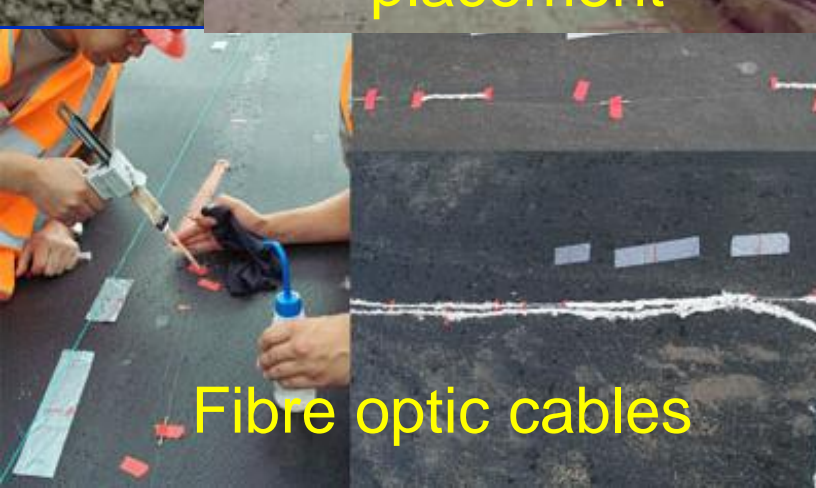

Fibre optic cables



Veneer experiment

# Summary and future

# Specification of testing

- Request information on the **type of direct shear device** to be used (e.g. fixity of top box, method used to apply normal stress)
- Consider the **test set up** in detail (e.g. geosynthetic restraint, gap size between top and bottom boxes)
- Consider in full the desired **properties of the soils** involved in the test (e.g. density) and likely behaviour (e.g. drained/undrained)
- **Select** the interface and direction of shearing, the number of tests, the normal stress range, dry or submerged and rate of shearing



# Obtaining strength parameters for design

- Strength and deformability properties control stability and integrity
- At present index tests predominate but these are of limited use in design
- **Performance tests** using site specific materials and boundary conditions must be carried out to provide engineering properties for use in design
- Investigations often show that a dearth of site specific interface shear strength data contributed to failure

# General good practice

- Tests should be specified and interpreted by experienced **geotechnical engineers**
- Conservative estimates (**characteristic values**) of shear strength are required (i.e. do not use measured values directly in design)
- In some cases low values are unconservative (e.g. when used to assess tensile forces in geosynthetic members)
- Design using **combined criteria** for factor of safety and probability of failure

# The future....

- Improved test specifications (enforcement of existing!)
- Better awareness and skills to specify tests
- More performance testing
- Rigorous determination of characteristic, and hence design, values
- Use of reliability based approaches to support design
- Engineering interfaces for specific applications.....

# Acknowledgements

- Research students: Anna Sia, Gary Fowmes, Kasia Zamara
- Russell Jones, Golder Associates (UK) Ltd
- Geofabrics, NAUE, ABG Ltd, Veolia
- Environment Agency

n.dixon@lboro.ac.uk